

efi sales Ltd.

Equipment for the Foodservice Industry

value + quality + service

Nugget Ice Machine

Model No:

IM-550-NUGGET



IM-550-NUGGET

Features

Features:

- Corrosion resistant
- Gliding door allows easy access to ice in the bin
- Simple and intuitive control panel
- A smaller nugget sized ice is softer and more chewable than standard cubes
- Ice scoop included
- Adjustable leveling legs

Warranty:

- One year parts and labour. *For full warranty details visit <https://www.efifoodequip.com/warranty-info.php>*



IM-550-NUGGET

Specifications

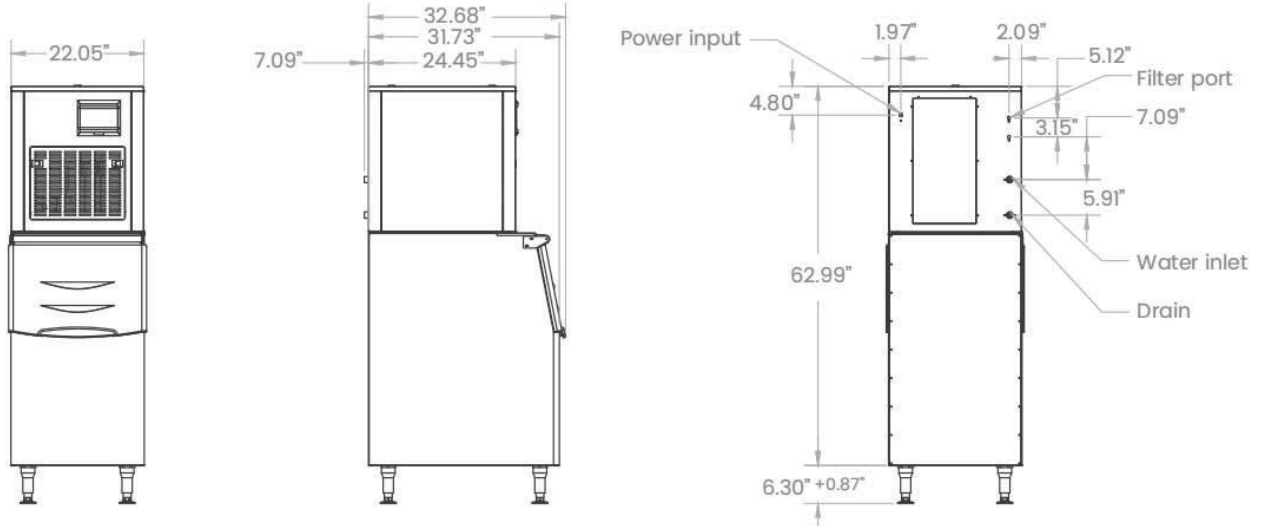

Model	Refrigerant	Dimension (mm) (inch)			Condenser Unit	Amps	Voltage (V/Hz)	Power (W)	Bin Capacity (kg) (lb)	Output LB/24hr (kg) (lb)	Net Weight (kg) (lb)
		W	D	H							
IM-550-NUGGET	R290	560	830	1760	Air	12	110/60	1180	125	250	89
		22	32.7	69.3					276	550	196

Specifications subject to change without notice.