

efi sales Ltd.

Equipment for the Foodservice Industry
value + quality + service

Cube Ice Machine

Model No:
IM-500



IM-500

Features

Features:

- Convenient, built-in scoop holder
- Easily removable baffle, no tools required for cleaning
- Light weight
- Corrosion resistant
- Ice scoop included
- Makes full cube sized ice

Warranty:

- One year parts and labour. For full warranty details visit <https://www.efifoodequip.com/warranty-info.php>



IM-500

Specifications

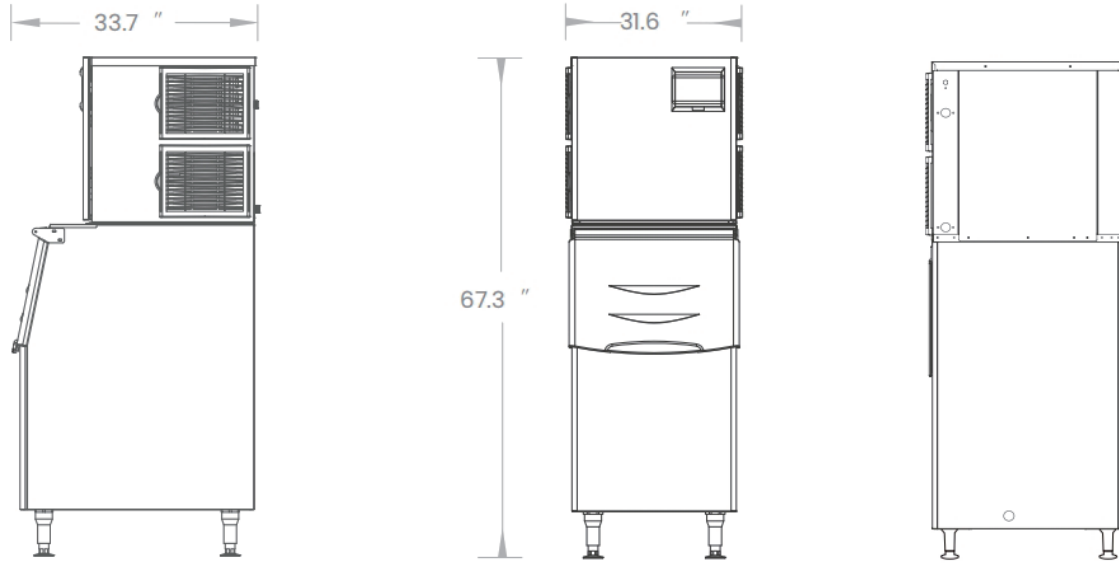

Model	Refrigerant	Dimension (mm) (inch)			Condenser Unit	Amps	Voltage (V/Hz)	Power (W)	Bin Capacity (kg) (lb)	Output LB/24hr (kg) (lb)	Net Weight (kg) (lb)
		W	D	H							
IM-500	R290	803	856	1709	Air	11.26	115/60	1113	170	225	120
		31.6	33.7	67.3					375	500	264

Specifications subject to change without notice.