

Project Name: _____ AIA#: _____

Model #: _____ Location: _____

SIS#: _____ Item #: _____ Quantity: _____



Electric Countertop Fryers

**Performance, Quality
and Economy — what you
get with Globe!**



PF16E



Frying Capacity

Model: PF10E - Fries per hour = 10 lbs.

Model: PF16E - Fries per hour = 25 lbs.

Model: PF32E - Fries per hour = 50 lbs.

Warming Temp Rates

- 7-10 minutes for initial oil warm up
- Oil recovery after each batch ~5 minutes (rate may vary with chilled/frozen foods)

Models

- PF10E - 10 lb. Oil Capacity Fryer
- PF16E - 16 lb. Oil Capacity Fryer (pictured)
- PF32E - 32 lb. Oil Capacity Fryer (dual tank)

Standard Features

- 70°F – 375°F thermostat
- High temp thermal limit control with manual reset
- 3½" stainless steel adjustable feet
- Built-in basket nesting hooks
- Attached 4-foot power cord and plug (dual power cords and plugs on the PF32E)
- All stainless steel construction
- Removable, stainless steel fry pot with handles
- Easy to remove and clean control box and swing up elements
- Nickel-plated fry baskets with cool-to-touch insulated handles

Warranty

- One-year parts and labor

Standard Accessories

- (2) Nickel-plated baskets

Applications

- Designed for light duty cooking
- Produces 10 to 50 lbs. of fries per hour – frozen to finish – depending on model

Optional Accessories/Attachments

- Interchangeable 16 lb. and 32 lb. baskets
 - Small basket - SMBASKET10*
 - Twin baskets - TMBASKET1632*
 - Large basket - LGBASKET1632*
- Fryer covers
 - FRYERCOVER1016*
 - FRYERCOVER32*
 - (For use only when fryer is not operational)*

To select options see back

Approved by: _____ Date: _____



Electric Countertop Fryers

PF10E / PF16E / PF32E

PF32E

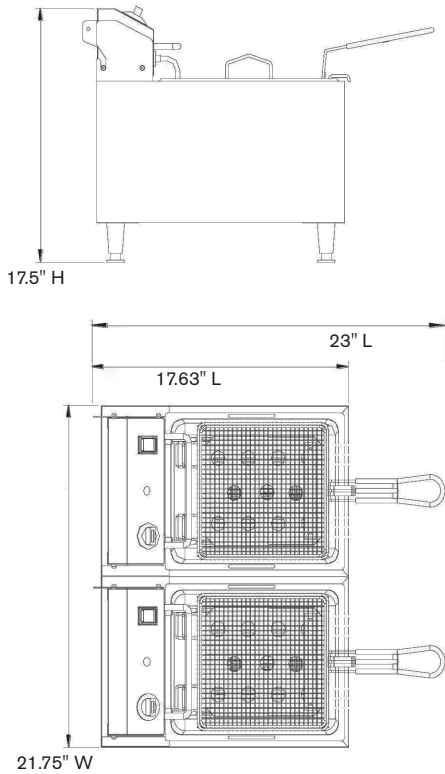

Oil Pan: 9.375" W x 11.75" L x 8" H
Basket Size: 8" W x 7.75" D x 6" H

PF16E

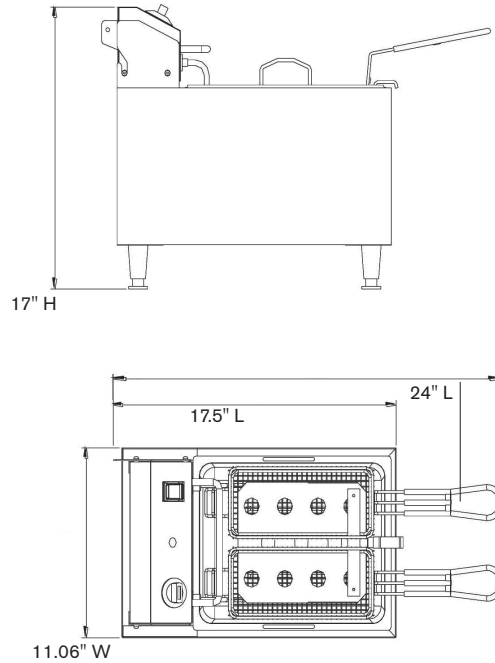

Oil Pan: 9.375" W x 11.75" L x 8" H
Basket Size: 4" W x 9" D x 6" H

PF10E

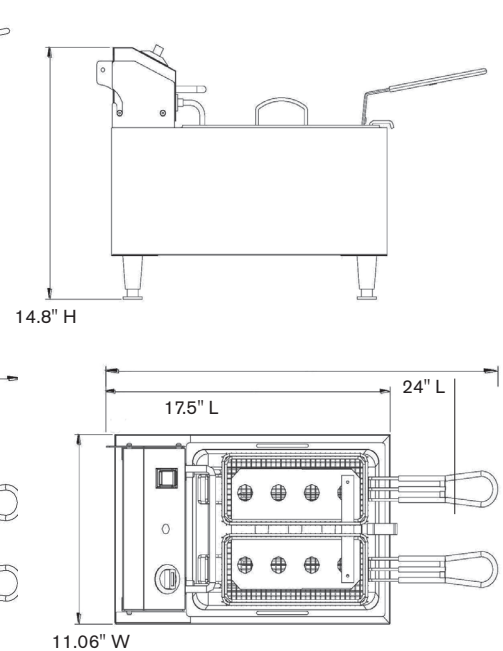

Oil Pan: 9.375" W x 11.75" L x 5.875" H
Basket Size: 4" W x 9" D x 4" H

For Indoor Use Only

SPECIFICATIONS

- All models come with two baskets. See basket sizes above
- Thermostat: Maintains oil/fat temperature for cooking from 70°F - 375°F.
- Thermal Limit Control HIGH TEMP: Detects high temperature limits and automatically shuts off the fryer.

Model	Food Capacity	Oil Capacity	# of Tanks	Electric	Wattage	AMPs	NEMA Plug Type
PF10E	~ 10 lbs per hour	10 lbs.	1	120V	1700 W	14	(1) 5-15P U.S.A. Ⓢ / (1) 5-20P Canada Ⓢ
PF16E	~ 25 lbs per hour	16 lbs.	1	208V 240V	2900W 3800W	13.9 15.8	(1) 6-20P U.S.A. & Canada Ⓢ
PF32E	~ 50 lbs per hour	32 lbs.	2 (Dual)	208V 240V	5800W 7600W	13.9 13.9 15.8 15.8	(2) 6-20P U.S.A. & Canada Ⓢ Ⓢ

DIMENSIONS | SHIPPING INFORMATION

Cartons are reinforced for shipping. The weight and dimensions of reinforced cartons are listed below and may vary from shipment to shipment.
Freight Class 85.

Model	Overall Dimensions	Net Weight	Shipping Dimensions	Shipping Weight
PF10E	17.5" L x 11.06" W x 14.8" H (44.45 cm x 28.01 cm x 37.6 cm)	16.3 lbs. (7.4 kg)	21.46" L x 14.76" W x 16.14" H (54.5 cm x 37.5 cm x 41 cm)	20.28 lbs. (9.2 kg)
PF16E	17.5" L x 11.06" W x 17" H (44.45 cm x 28.01 cm x 43.18 cm)	18.96 lbs. (8.6 kg)	21.46" L x 14.76" W x 17.91" H (54.5 cm x 37.5 cm x 45.5 cm)	22.93 lbs. (10.4 kg)
PF32E	17.63" L x 21.75" W x 17.5" H (44.78 cm x 55.25 cm x 44.45 cm)	30.42 lbs. (13.8 kg)	25.39" L x 21.46" W x 17.91" H (64.5 cm x 54.5 cm x 45.5 cm)	37.04 lbs. (16.8 kg)

OPTIONS:

- Interchangeable 16 lb. and 32 lb. baskets:

- Small basket - SMBASKET10
- Twin baskets - TMBASKET1632
- Large basket - LGBASKET1632

- Fryer covers - FRYERCOVER1016
FRYERCOVER32

(For use only when fryer is not operational)

Canada orders: Please specify -C after the model number for CSA plug