



Equipment for the Foodservice Industry  
value + quality + service

## 60" Refrigerated Mega Top Prep Table

Model No:  
**CMDR2-60VC**



### CMDR2-60VC

### Features

#### Features:

- Front breathing, side mount compressor
- Exterior & interior stainless steel construction
- Environmentally friendly R290 refrigerant
- Includes 24 (1/6-size), 4" deep clear polycarbonate food pans in countertop prep area
- Full length removable cutting board included
- Heavy duty Embraco compressor
- Self-closing and stay open door
- Efficient refrigeration system
- Recessed door handle
- Magnetic door gaskets

- Casters for easy movement
- Pre-installed shelves

#### Warranty:

- Two year parts and labour; Five years on compressor. *For full warranty details visit <https://www.efifoodequip.com/warranty-info.php>*



**CMDR2-60VC Specifications**

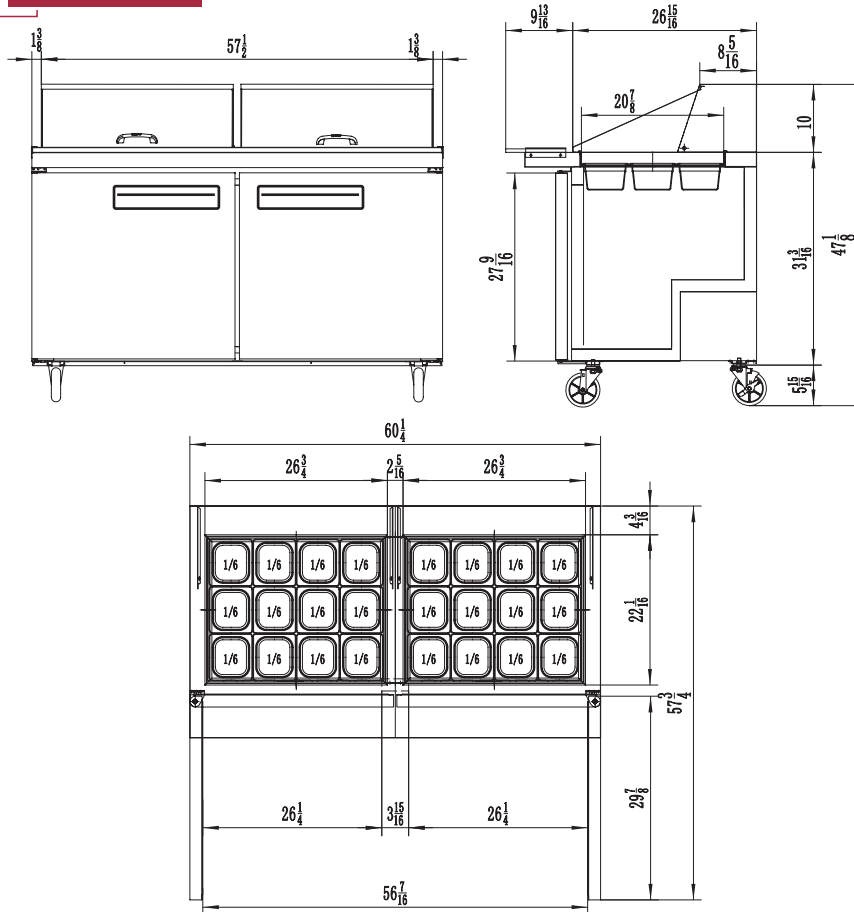

Model	Refrigrant	Doors	Shelves	Dimension (mm) (inch)			HP	Voltage	Amps	Capacity (L) (Cu Ft.)	Net Weight (KG) (LBS)	Temperature Range
				W	D	H						
CMDR2-60VC	R290	2	2	1530	863	1196	1/5	115/60	2.8	586	129	1 ~ 8°C
				60.2	34.0	47.1				20.7	284	33 ~ 45°F

Equipped with one NEMA 5-15P plug 

**Shipping Information**

Crate Dimensions (mm) (inch)			Net Weight (KG) (LBS)	Gross Weight (KG) (LBS)
W	D	H		
1585	932	1247	129	154
62.4	36.7	49.1	284	340

Specifications subject to change without notice.