



Equipment for the Foodservice Industry
value + quality + service

48" Refrigerated Salad/ Sandwich Prep Table

Model No:
CSDR2-48VC



CSDR2-48VC

Features

Features:

- Front breathing, side mount compressor
- Exterior & interior stainless steel construction
- Environmentally friendly R290 refrigerant
- Includes 18 (1/6-size), 4" deep clear polycarbonate food pans in countertop prep area
- Full length removable cutting board included
- Heavy duty Embraco compressor
- Self-closing and stay open door
- Efficient refrigeration system
- Recessed door handle
- Magnetic door gaskets

- Casters for easy movement
- Pre-installed shelves

Warranty:

- Two year parts and labour; Five years on compressor. *For full warranty details visit <https://www.efifoodequip.com/warranty-info.php>*



CSDR2-48VC

Specifications

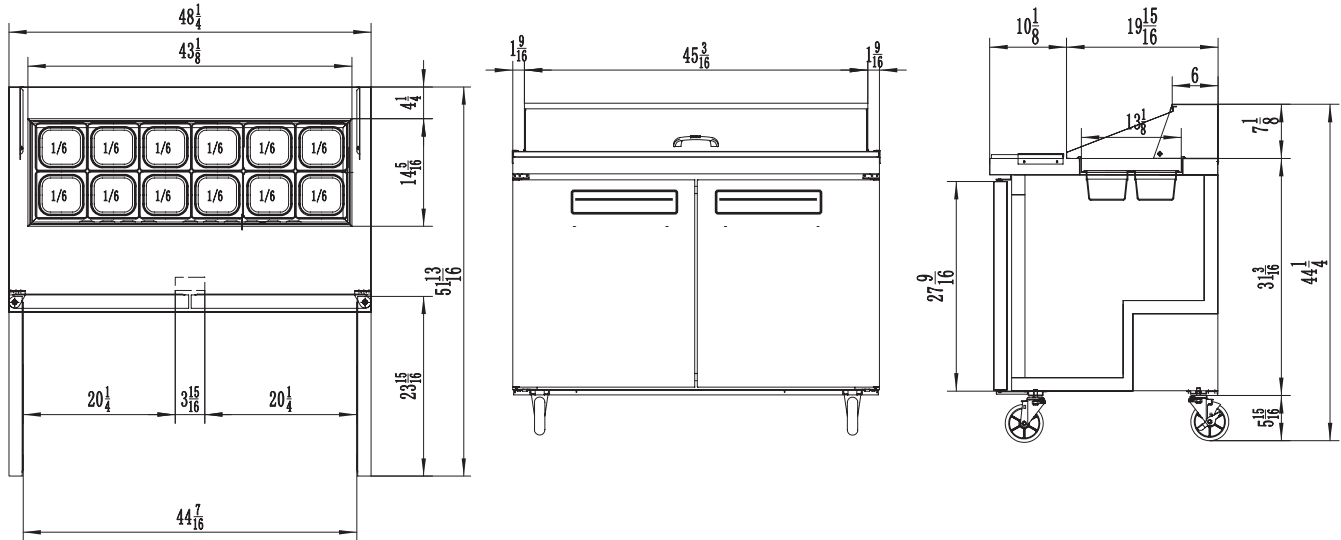

Model	Refrigerant	Doors	Shelves	Dimension (mm) (inch)			HP	Voltage	Amps	Capacity (L) (Cu Ft.)	Net Weight (KG) (LBS)	Temperature Range
				W	D	H						
CSDR2-48VC	R290	2	2	1225	762	1125	1/6	115/60	2.3	379	105	1 ~ 8°C
				48.2	30.0	44.3				13.4	231	33 ~ 45°F

Equipped with one NEMA 5-15P plug 

Shipping Information

Crate Dimensions (mm) (inch)			Net Weight (KG) (LBS)	Gross Weight (KG) (LBS)
W	D	H		
1280	831	1186	105	125
50.4	32.7	46.7	231	276

Specifications subject to change without notice.