

**efi** sales Ltd.

Equipment for the Foodservice Industry  
value + quality + service

**COUNTERTOP GLASS  
DOOR FREEZER**

F1-50GDCT-L



**F1-50GDCT-L**

**Features**

Features:

- 50 L countertop display freezer with light box
- Tempered glass door for maximum product visibility
- Black exterior with white interior
- Digital temperature control
- Direct cooling by compressor
- Adjustable temperature range between -22°C - -18°C

- LED interior lighting
- Adjustable shelves

Warranty:

- One year parts and labour; Five years on compressor. For full warranty details visit <https://www.efifoodequip.com/warranty-info.php>



**F1-50GDCT-L Specifications**

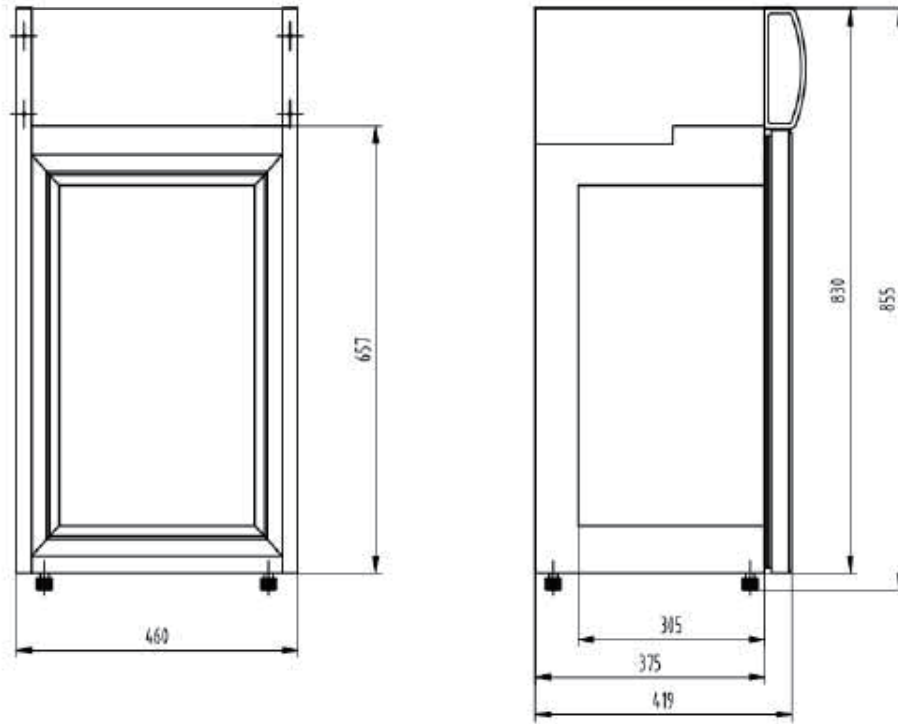

Model	Refrigerant	Door Type	Shelves	Dimension (mm / inch)			Voltage	Power	Capacity	Net Weight (KG / LBS)	Temperature Range
				W	D	H					
F1-50GDCT-L	R290	Swing	3	460	495	855	110/60	130 W	50 L	35	-22 ~ -18°C
				18.1	19.5	33.7				77.2	-8 ~ 0°F

Equipped with one NEMA 5-15P plug

**Shipping Information**

Crate Dimensions (mm / inch)			Net Weight (KG / LBS)	Gross Weight (KG / LBS)
W	D	H		
542	539	909	35	39
21.3	21.2	35.8	77.2	86.0

Specifications subject to change without notice.