

# ZESTO

## Gas Conveyor Oven CG 4832



- \* 32" (81cm) conveyor belt.
- \* Stainless Steel Construction.
- \* Front mount controls for easy view and access.
- \* Electronic temperature control with digital read-out.
- \* Variable digital speed control on conveyor belt.
- \* Cook time from 1 - 20 minutes.
- \* Reversible conveyor belt direction.
- \* Thermally insulated for energy efficiency.

- \* Efficient power Gas Burner
- \* High velocity precision targeted air flow distribution panels for consistent repeatable baking results.
- \* Stackable (up to 2 units high).
- \* Removable front panel, crumb tray, top and bottom air flow distribution panels for easy cleaning.
- \* Legs with locking casters (17", 23" or 29" available)



**Ideal for a variety of cooking applications including pizza, seafood, omelettes and other egg dishes, pre-cooked meats, cookies, bakery products, pita breads, heating plated Mexican food and hot submarine sandwiches.**

# Gas Conveyor Oven CG 4832



Conforms to: ANSI Std. Z83.11  
Conforms to: CGA Std. 1.8



Conforms to:  
Std. NSF-4

**Gas connection:**  
Equipped with 3/4" NPT gas connection at rear.

**Electrical:**  
Ovens are equipped with 6' electrical cord with 20 amps plug (120 volts).

**Ventilation:**  
Proper ventilation is required.  
Must be installed under ventilation hood.

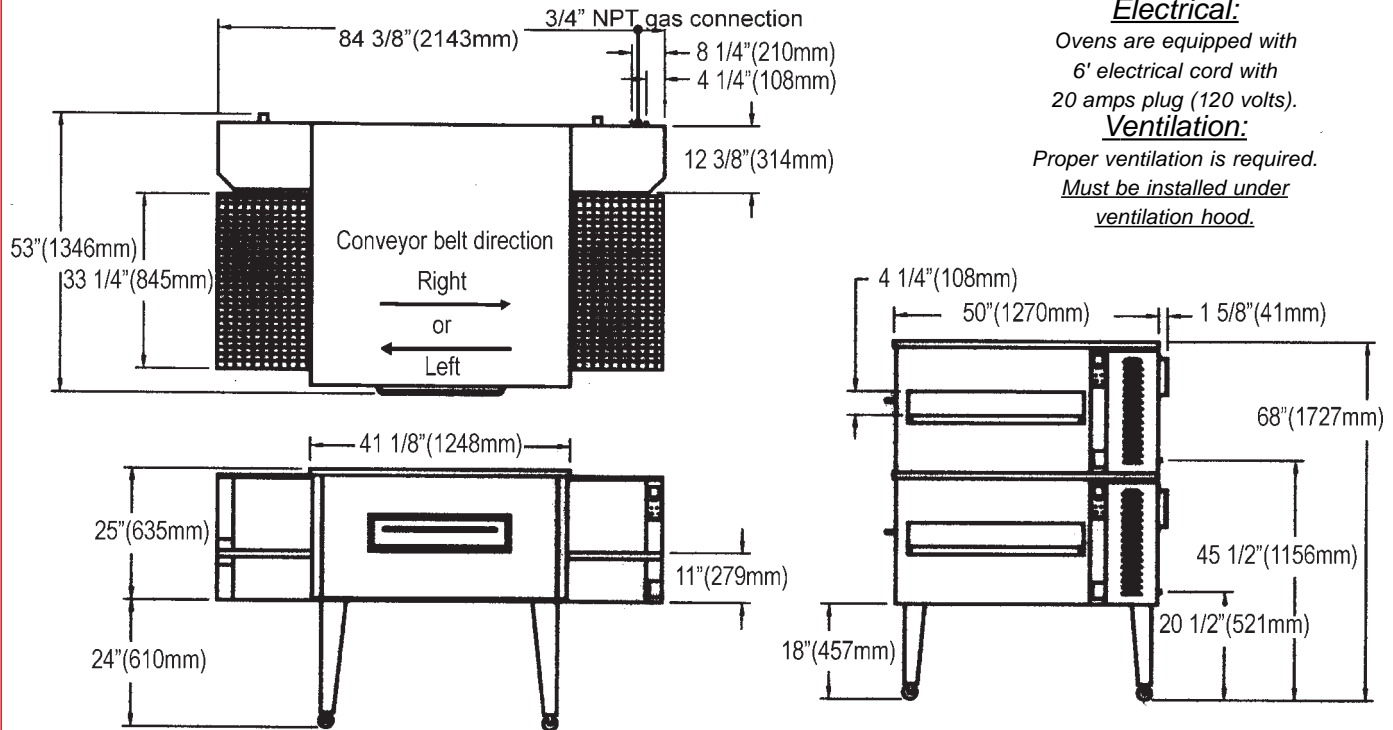

<b>Approximate production per hour / per section / bake time in minutes (4832)</b>							
Pan diameter	5 min	6 min	6.45 min	7 min	7.5 min	8 min	9 min
6" (15 cm)	510	423	393	362	339	318	281
8" (20 cm)	285	237	220	202	189	178	157
10" (25 cm)	181	151	139	129	119	113	101
12" (30 cm)	125	103	96	89	83	78	69
14" (35 cm)	91	75	69	65	59	56	50
16" (40 cm)	70	57	52	49	45	43	38

Cooking Chamber 48" (121.9 cm) long X 32" (81 cm) deep

Model	B.T.U.	Exterior dimensions	Length of belt	Voltages	Ship wt..
CG 4832	140,000	84"L x 50"D 213cm x 127cm	84"L x 32"D 213cm x 81cm	120v / 1 $\phi$ (13.5 amps) 208v - 240v / 1 $\phi$ (8 amps)	1050 lbs 476 kg

Propane or Natural gas, also available in 50 or 60 cycles

**ZESTO** FOOD EQUIPMENT MANUFACTURING INC.  
MANUFACTURIER D'EQUIPEMENT EN ALIMENTATION INC.

6450 HUTCHISON, MONTREAL, QC, CANADA H2V 4C8  
TEL(514)278-4621 FAX(514)278-4622  
e-mail info@zesto.ca www.zesto.ca

SPECIFICATIONS SUBJECT TO CHANGE WITHOUT NOTICE.

LES SPÉCIFICATIONS SONT SUJETS À CHANGEMENT SANS AVIS.