

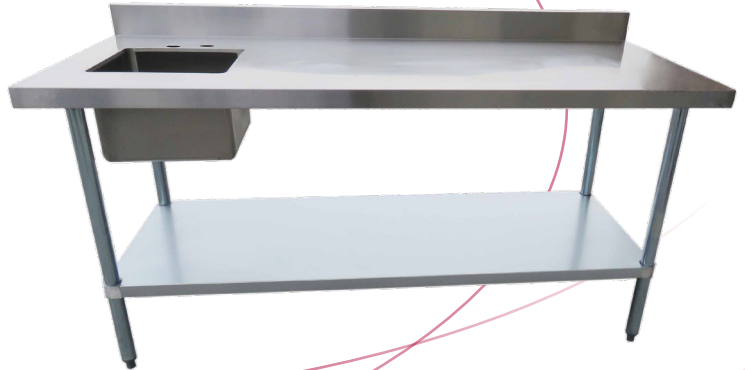

Equipment for the Foodservice Industry
value + quality + service

Worktable with Sink Left with Backsplash



Worktables with Sink Left with Backsplash

Features

Features:

- 4" backsplash
- Sinks come with 1 7/8" center drain hole and come with drain mini-basket
- Sinks come with 4" center pre-cut holes for standard deck mount faucet (faucet not included)
- Heavy duty, 18 gauge, Type 430 stainless steel top provides long life
- Top is TIG welded
- Entire top surface is machine polished to a satin finish
- Reinforced to exceed industry standards
- Galvanized hat channels are secured to top by structural adhesive and weld studs
- Gussets welded to support hat sections
- Hemmed edges provide strength and safety
- Simple assembly
- Shipped unassembled for reduced cost and space
- Galvanized legs and undershelf for durability and economy
- Die cast reinforced leg sockets for stability
- Legs are 1 5/8" diameter
- Adjustable ABS bullet feet to accommodate uneven flooring
- 84" and above have 6 legs
- Specifications subject to change without notice.

Worktables with Sink Left with Backsplash

Specifications

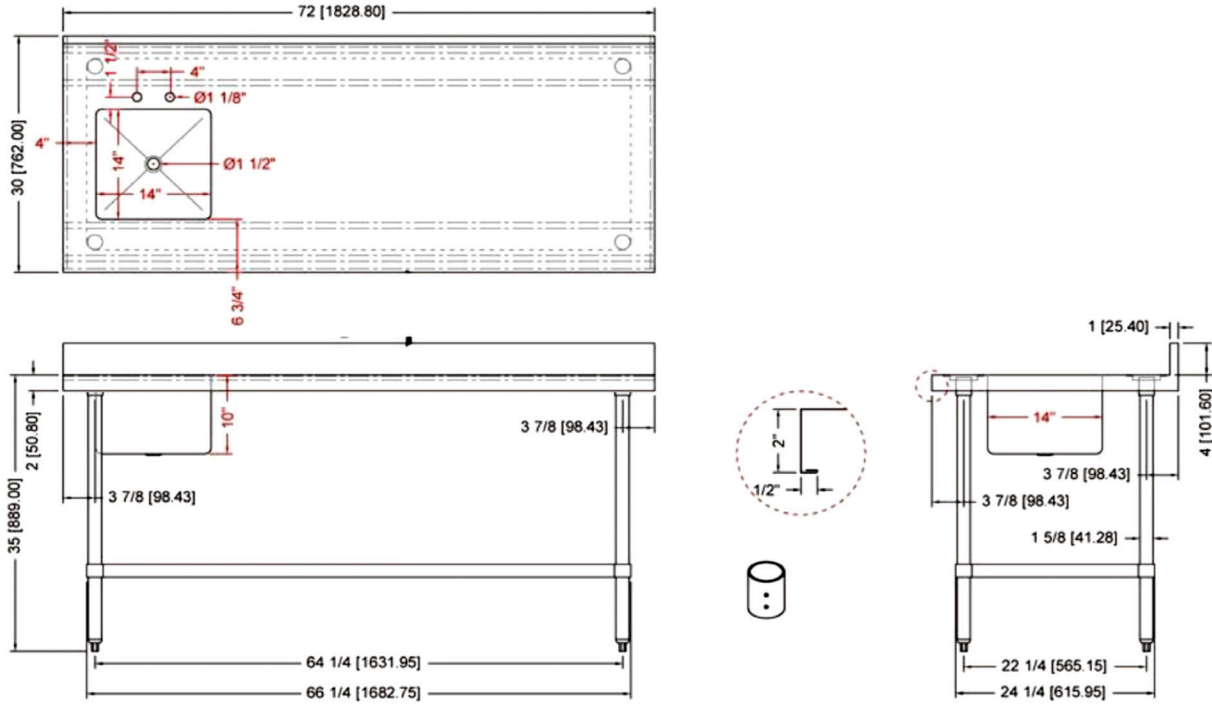

WORKTABLES WITH SINK LEFT AND BACKSPLASH 24" DEPTH

Product #	Width	Shipping Dimensions			Weight (lbs)
		L"	W"	H"	
TTUBL2448-B	48	50	26	15	95
TTUBL2460-B	60	62	26	15	113
TTUBL2472-B	72	74	26	15	119
TTUBL2484-B	84	86	26	15	125
TTUBL2496-B	96	98	26	15	136

WORKTABLES WITH SINK LEFT AND BACKSPLASH 30" DEPTH

Product #	Width	Shipping Dimensions			Weight (lbs)
		L"	W"	H"	
TTUBL3048-B	48	50	32	15	104
TTUBL3060-B	60	62	32	15	117
TTUBL3072-B	72	74	32	15	133
TTUBL3084-B	84	86	32	15	148
TTUBL3096-B	96	98	32	15	164