

efi sales Ltd.

Equipment for the Foodservice Industry

value + quality + service

Novelty Refrigeration

FCCG-60

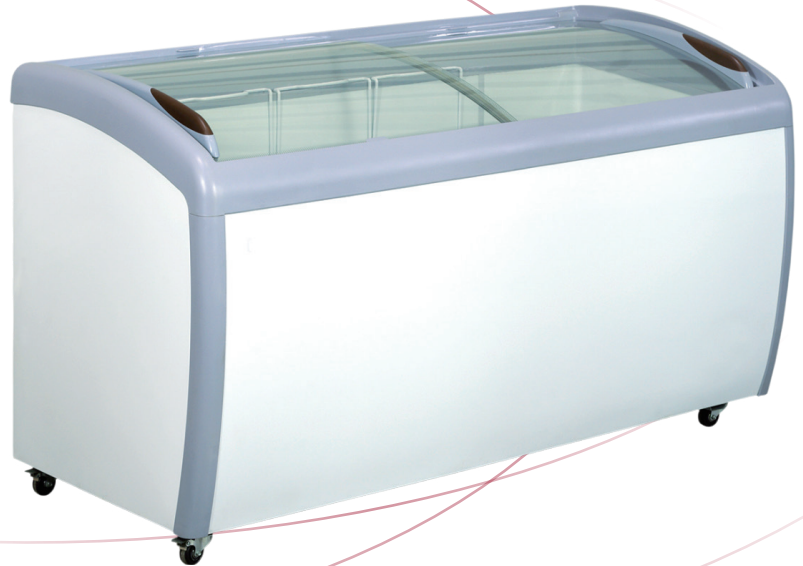

FCCG-60

Features

Features:

- Durable white powder coated steel exterior with white precoated steel interior
- Temperature display
- PVC coated baskets included
- Sliding doors with curved top glass for easy access
- Built in lock to secure products
- Eco-friendly R-290 refrigerant
- Low profile casters with locks

Warranty:

- One year limited warranty parts and labour.
For full warranty details visit <https://www.efifoodequip.com/warranty-info.php>



FCCG-60

Specifications

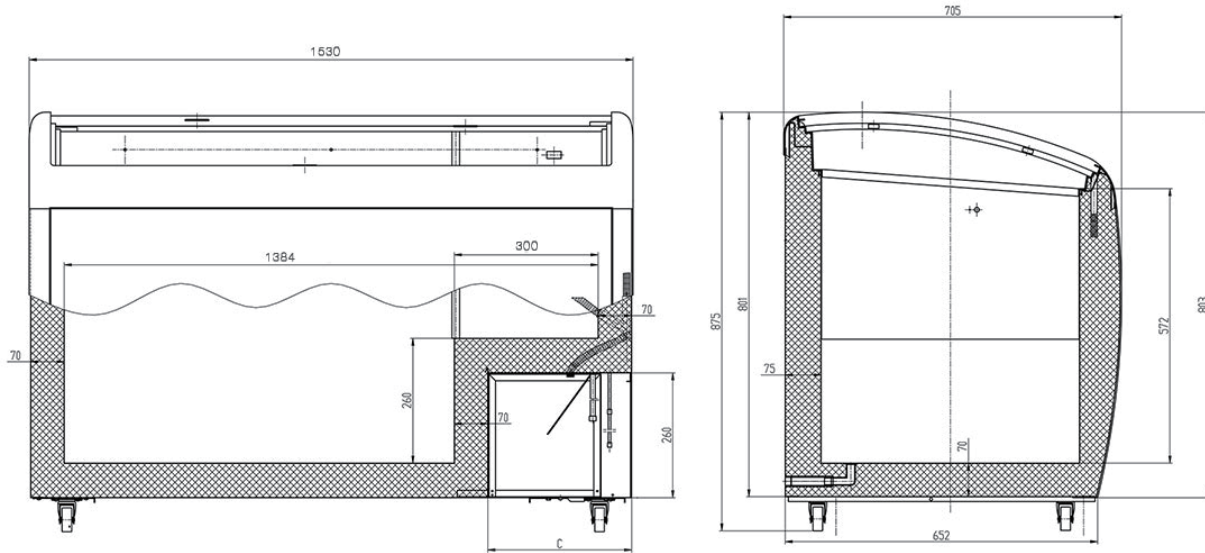

Model	Baskets	Dimension (mm) (inch)			HP	Voltage	Amps	Capacity (L) (Cu Ft.)	Net Weight (KG) (LBS)	Temperature Range	NEMA Config.
		L	D	H							
FCCG-60	4	1530	705	875	1/2+	115/60/1	4	458.7	87	≤ -26°C	5-15A
		60	27.8	34.5				16.2	192	≤ -15°F	

Equipped with one NEMA 5-15P plug 

Specifications subject to change without notice.