

REL-WB100 Electric Water Boiler 100 Cup/15 Litre



- Boils 100 cups (5 oz.) in less than 70 minutes
- Contemporary styling
- 2-way, non-drip spigot with locking feature
- Higher clearance spigot accommodates larger cups
- Dual, high-limit thermostat protects against overheating
- Keep warm function
- Boil-dry protection
- Double-wall stainless steel construction
- Stainless steel components for easy cleaning
- Twist-to-secure cover with stay-cool handles
- Brew-view gauge with internal water level markings
- On/off switch with waterproof cover
- Indicator lights: Red: Brewing; Amber: Ready / Keep Warm
- 6-month limited warranty*
Warranty void if used to heat any liquids other than water



Dimensions (WxDxH)	14.5"x15"x20.25"
Electrical	120V, 1100W, 60HZ, NEMA 5-15P Plug
Net weight (kg)	3.95
Gross weight (kg)	5.05

Specifications subject to change without notice.

*6-month warranty valid from date of purchase, with accompanying invoice.
Warranty void if used to heat any liquids other than water.

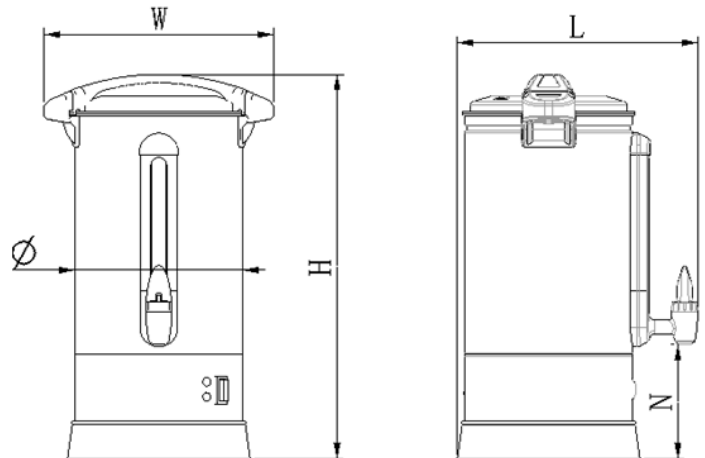

Φ MM	W (MM)	H (MM)	L (MM)	N (MM)
290	370	515	385	160

For complete information and specifications on all Reliant products, visit www.paragondirect.ca