

CONTENTS

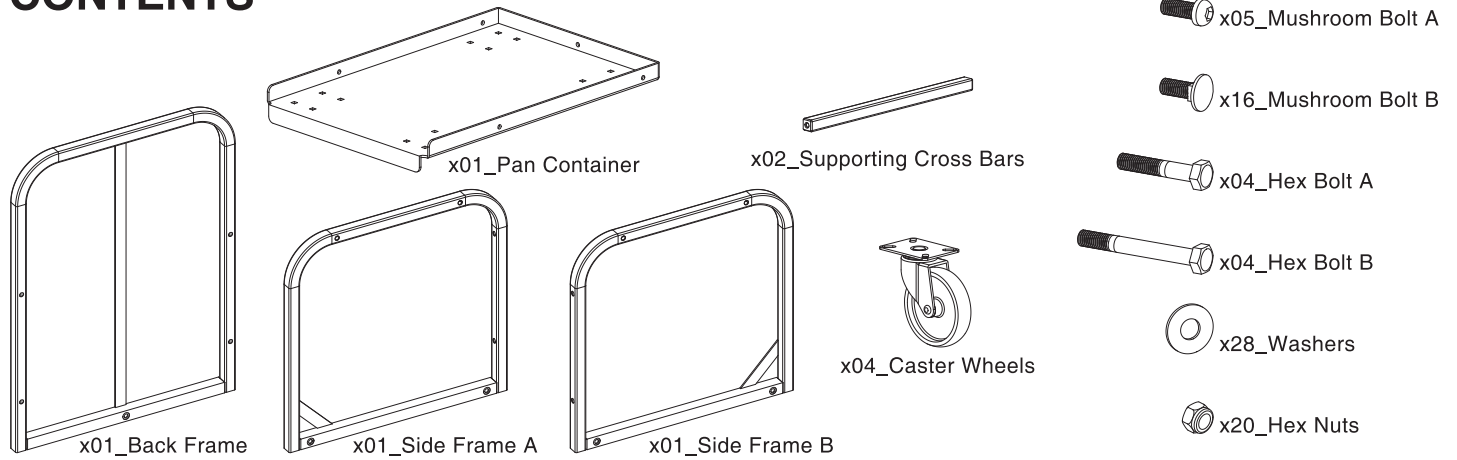

*Contents are not to scale to each other

1 ASSEMBLE THE FRAME

- Connect the side frame to the pan container with washer and mushroom bolt A
- >> Repeat on other side frame

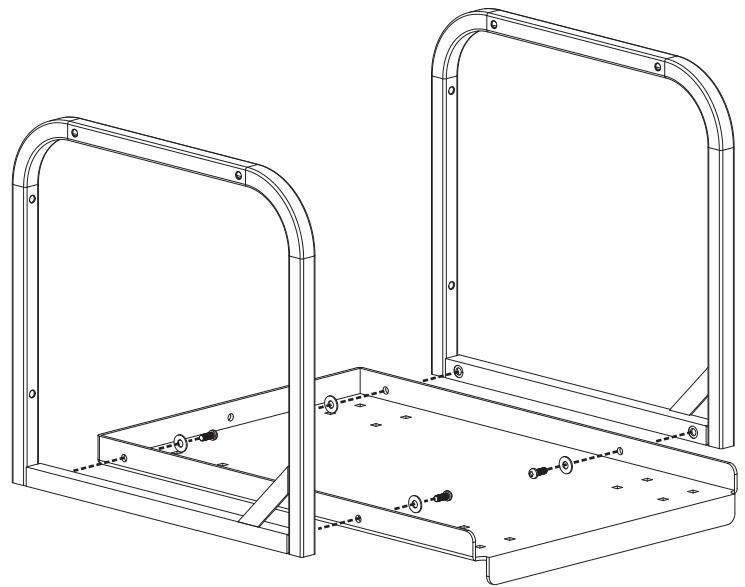
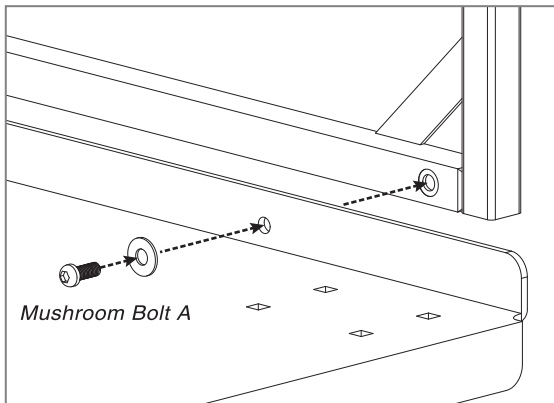

2 ATTACH THE CROSS BARS

- Align the holes of the side frames and cross bars
- Connect with washer and hex bolt A
- >> Repeat on other bars on both sides

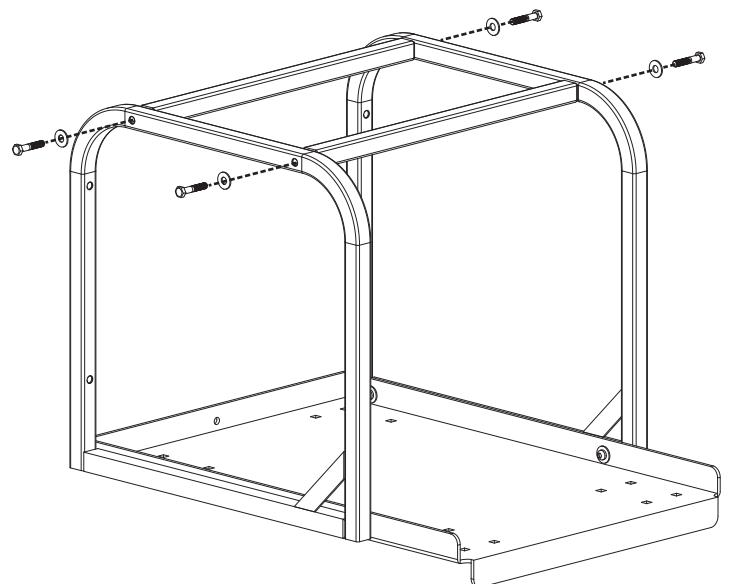
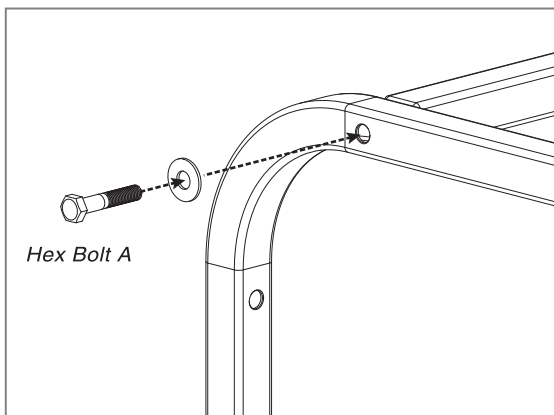

3 ATTACH THE CASTER WHEELS

- Turn the frame on its side
- Connect the caster wheel to pan container with mushroom bolt B, washers, and hex nuts.
- >> Repeat for remaining caster wheels

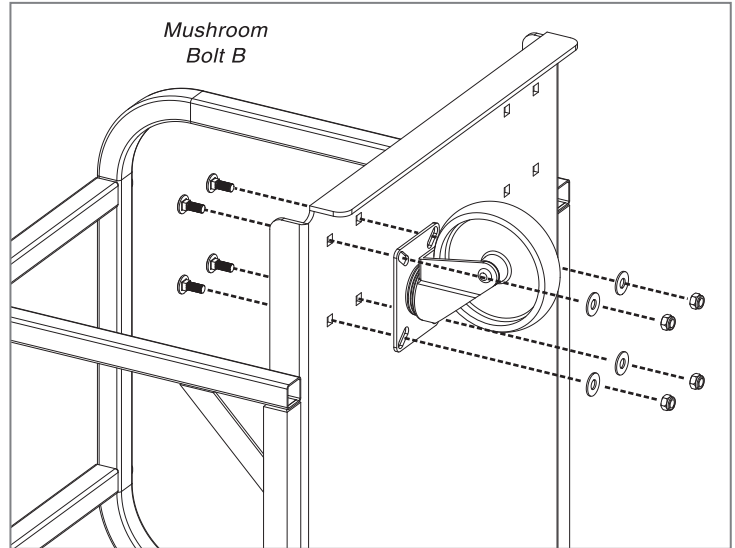

4 ATTACH THE BACK FRAME

- Turn the truck upright
- Connect the back frame to the pan container with washer and mushroom bolt A
- Connect the back frame to the pan container with hex bolt B, washer, and hex nut

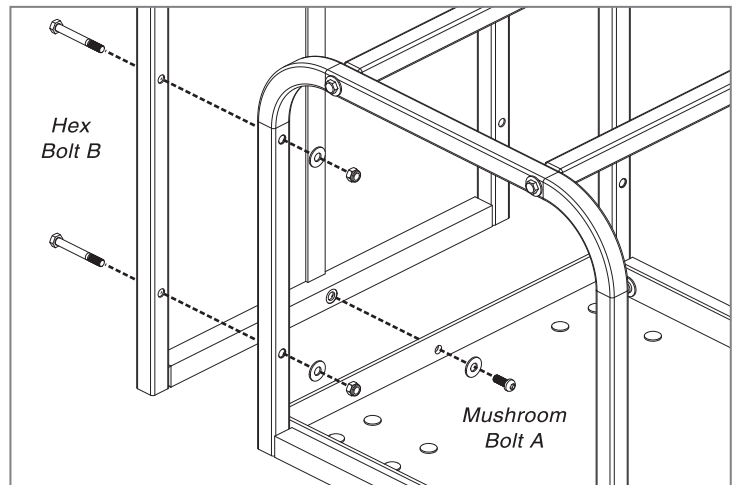

5 FINAL CHECK

- Stand the truck upright on a level surface/floor.
- All casters must be touching the floor evenly.
- Firmly tighten all bolts to ensure they are secure.



CAUTION

DO NOT OVERTIGHTEN BOLTS .

Overtightening may cause stripped threads and the bolt will not function properly.

