

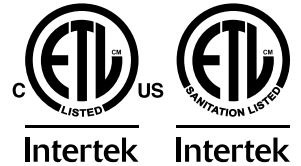

**Refrigerated Showcase**  
**Model RS-CN-0468**  
**Item 47277**  
**Instruction Manual**



*Revised - 11/17/2021*



Toll Free: 1-800-465-0234  
Fax: 905-607-0234  
Email: [service@omcan.com](mailto:service@omcan.com)  
[www.omcan.com](http://www.omcan.com)

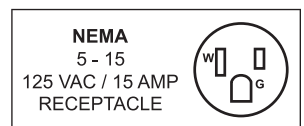

# ***Table of Contents***

Model RS-CN-0468

---

<b>Section</b>	<b>Page</b>
Disclaimer -----	3
General Information -----	4 - 5
Safety and Warranty -----	5 - 7
Technical Specifications -----	8
Operation -----	8 - 10
Maintenance -----	10
Troubleshooting -----	11 - 12
Parts Breakdown -----	13 - 15
Electrical Schematics -----	16
Notes -----	17 - 18
Warranty Registration -----	19

***OMCAN IS NOT RESPONSIBLE FOR DIMINISHED COOLING OR ANY DAMAGES DUE TO WATER LEAKS. WARRANTY IS VOID IF THE AMBIENT ROOM TEMPERATURE EXCEEDS 75°F AND 55% RELATIVE HUMIDITY, AND THE APPLIANCE DRAIN IS NOT CONNECTED DIRECTLY TO A FLOOR DRAIN.***

# ***General Information***

---

**Omcan Manufacturing and Distributing Company Inc., Food Machinery of America, Inc. dba Omcan and Omcan Inc. are not responsible for any harm or injury caused due to any person's improper or negligent use of this equipment. The product shall only be operated by someone over the age of 18, of sound mind, and not under the influence of any drugs or alcohol, who has been trained in the correct operation of this machine, and is wearing authorized, proper safety clothing. Any modification to the machine voids any warranty, and may cause harm to individuals using the machine or in the vicinity of the machine while in operation.**

## **CHECK PACKAGE UPON ARRIVAL**

Upon receipt of an Omcan shipment please inspect for external damage. If no damage is evident on the external packaging, open carton to ensure all ordered items are within the box, and there is no concealed damage to the machine. If the package has suffered rough handling, bumps or damage (visible or concealed), please note it on the bill of lading before accepting the delivery and contact Omcan within 24 hours, so we may initiate a claim with the carrier. A detailed report on the extent of the damage caused to the machine must be filled out within three days, from the delivery date shown in the shipping documents. Omcan has no recourse for damaged products that were shipped collect or third party.

**Before operating any equipment, always read and familiarize yourself with all operation and safety instructions.**

**Omcan would like to thank you for purchasing this machine. It's of the utmost importance to save these instructions for future reference. Also save the original box and packaging for shipping the equipment if servicing or returning of the machine is required.**

---

**Omcan Fabrication et distribution Compañie Limité et Food Machinery d'Amérique, dba Omcan et Omcan Inc. ne sont pas responsables de tout dommage ou blessure causé du fait que toute personne ait utilisé cet équipement de façon irrégulière. Le produit ne doit être exploité que par quelqu'un de plus de 18 ans, saine d'esprit, et pas sous l'influence d'une drogue ou d'alcool, qui a été formé pour utiliser cette machine correctement, et est vêtu de vêtements de sécurité approprié. Toute modification de la machine annule toute garantie, et peut causer un préjudice à des personnes utilisant la machine ou des personnes à proximité de la machine pendant son fonctionnement.**

## **VÉRIFIEZ LE COLIS DÈS RÉCEPTION**

Dès réception d'une expédition d'Omcan veuillez inspecter pour dommages externes. Si aucun dommage n'est visible sur l'emballage externe, ouvrez le carton afin de s'assurer que tous les éléments commandés sont dans la boîte, et il n'y a aucun dommage dissimulé à la machine. Si le colis n'a subi aucune mauvaises manipulations, de bosses ou de dommages (visible ou cachée), notez-le sur le bond de livraison avant d'accepter la livraison et contactez Omcan dans les 24 heures qui suivent, pour que nous puissions engager une réclamation auprès du transporteur. Un rapport détaillé sur l'étendue des dommages causés à la machine doit être rempli dans un délai de trois jours, à compter de la date de livraison indiquée dans les documents d'expédition. Omcan n'a aucun droit de recours pour les produits endommagés qui ont été expédiés ou cueilli par un tiers transporteur.



# General Information

---

Avant d'utiliser n'importe quel équipement, toujours lire et vous familiariser avec toutes les opérations et les consignes de sécurité.

Omcan voudrais vous remercier d'avoir choisi cette machine. Il est primordial de conserver ces instructions pour une référence ultérieure. Également conservez la boîte originale et l'emballage pour l'expédition de l'équipement si l'entretien ou le retour de la machine est nécessaire.

---

Omcan Empresa De Fabricacion Y Distribucion Inc. Y Maquinaria De Alimentos De America, Inc. dba Omcan y Omcan Inc. no son responsables de ningun daño o perjuicio causado por cualquier persona inadecuada o el uso descuidado de este equipo. El producto solo podra ser operado por una persona mayor de 18 años, en su sano juicio y no bajo alguna influencia de droga o alcohol, y que este ha sido entrenado en el correcto funcionamiento de esta máquina, y ésta usando ropa apropiada y autorizada. Cualquier modificación a la máquina anula la garantía y puede causar daños a las personas usando la máquina mientras esta en el funcionamiento.

## REVISE EL PAQUETE A SU LLEGADA

Tras la recepcion de un envio Omcan favor inspeccionar daños externos. Si no hay daños evidentes en el empaque exterior, Habra el carton para asegurarse que todos los articulos solicitados estén dentro de la caja y no encuentre daños ocultos en la máquina. Si el paquete ha sufrido un manejo de poco cuidado, golpes o daños (visible o oculto) por favor anote en la factura antes de aceptar la entrega y contacte Omcan dentro de las 24 horas, de modo que podamos iniciar una reclamación con la compañía. Un informe detallado sobre los daños causados a la máquina debe ser llenado en el plazo de tres días, desde la fecha de entrega que se muestra en los documentos de envío. Omcan no tiene ningun recurso por productos dañados que se enviaron a recoger por terceros.

Antes de utilizar cualquier equipo, siempre lea y familiarizarse con todas las instrucciones de funcionamiento y seguridad.

Omcan le gustaría darle las gracias por la compra de esta máquina. Es de la mayor importancia para salvar estas instrucciones para futuras consultas. Además, guarda la caja original y el embalaje para el envío del equipo si servicio técnico o devolución de la máquina que se requiere.

# Safety and Warranty

---

<b>Handle with care</b>	<b>Dry place</b>
Unplug the wall socket first. Never tilt it over 45 degrees when handling.	Always place the refrigerator in a dry location.

# Safety and Warranty

<p><b>Sufficient space</b> The distance from both sides and back of refrigerator to wall or other substance must be no less than 10 cm (4"). The refrigeration capability may decrease if its surrounding space is too small to circulate air.</p>	<p><b>Well ventilated</b> Always place the refrigerator in an area with proper ventilation. When using for the first time, wait at least 24 hours after handling to start.</p>
<p><b>Far from heat source</b> Never place the refrigerator in direct sunlight. Never place refrigerator near heat source as it reduces refrigeration capabilities.</p>	<p><b>Heavy load</b> Never put any heavy objects on top of the refrigerator.</p>
<p><b>Do not make holes</b> Never make any holes on the refrigerator. Do not attach any objects onto the refrigerator.</p>	<p><b>Stable Location</b> Unpack and place the refrigerator on level and stable ground.</p>
<p><b>Exclusive power socket</b> Normally, the power supply should be 100 – 120V, 60 Hz single phase AC with exclusive single phase receptacle.</p>	<p><b>Do not share the socket</b> Never let the refrigerator share a socket with another appliance. The cable may become hot and this may cause a fire.</p> <p><b>DO NOT USE EXTENSION CORDS.</b></p>
<p><b>Protect cables</b> Never break or damage the cables as this may cause current leakage resulting in a fire.</p>	<p><b>No water flushing</b> Never spray down refrigerator with pressurized water supply.</p>
<p><b>Avoid flammable and explosive objects</b> Never put any flammable or explosive items inside the refrigerator such as gasoline or alcohol. Never put any dangerous products in close proximity to the refrigerator.</p>	<p><b>No spray</b> Do not spray the unit with a flammable substance such as paint. This may result in a fire.</p>
<p><b>After power break</b> After a power break or unplugging the refrigerator, always wait at least 5 minutes before starting the refrigerator again.</p>	<p><b>Medical Storage</b> No medicine is allowed to be kept inside the refrigerator.</p>

## NOTE

- The electric circuit diagram and parameters on the product name plate are subject to change without the manufacturer having to change the manual.
- The design might be improved without notice.
- If the power cord is damaged, it must be replaced by the manufacturer, its service agent or a qualified electrician in order to avoid injury.

**WARNING: The unit uses R290 refrigerant. Make sure that all precautions against fire have been taken.**

**RESIDENTIAL USERS: Vendor assumes no liability for parts or labor coverage for component failure**



# *Safety and Warranty*

---

or other damages resulting from installation in non-commercial or residential applications. The right is reserved to deny shipment for residential usage; if this occurs, you will be notified as soon as possible.

## **1 YEAR PARTS AND LABOUR WARRANTY**

Within the warranty period, contact Omcan Inc. at 1-800-465-0234 to schedule an Omcan authorized service technician to repair the equipment locally.

Unauthorized maintenance will void the warranty. Warranty covers electrical and part failures, not improper use.

Please see <https://omcan.com/disclaimer> for complete info.

### **WARNING:**

The packaging components are classified as normal solid urban waste and can therefore be disposed of without difficulty.

In any case, for suitable recycling, we suggest disposing of the products separately (differentiated waste) according to the current norms.

**DO NOT DISCARD ANY PACKAGING MATERIALS IN THE ENVIRONMENT!**

# Technical Specifications

<b>Model</b>	<b>RS-CN-0468</b>
<b>Capacity</b>	468 L / 16.53 cu.ft
<b>Temperature Range</b>	2 - 10°C / 35.6 - 50°F
<b>Max Ambient Temp Rating</b>	32°C / 90°F
<b>Refrigeration Power</b>	1298 W
<b>Defrost Power</b>	36.8 W
<b>Electrical</b>	110V / 60Hz / 1
<b>Current</b>	10.7A
<b>Refrigerant</b>	R290
<b>Top Shelf Capacity</b>	44.1 lbs. / 20 kgs.
<b>Bottom Shelf Capacity</b>	44.1 lbs. / 20 kgs.
<b>Weight</b>	522.5 lbs. / 237 kgs.
<b>Packaging Weight</b>	650.4 lbs. / 295 kgs.
<b>Dimensions</b>	47.2" x 34.1" x 59.1" / 1200 x 865 x 1500mm
<b>Packaging Dimensions</b>	50.8" x 38.4" x 65" / 1290 x 975 x 1650mm
<b>Item Number</b>	47277

## Operation

### BEFORE USE

Ensure the unit is upright and positioned in its location for 12 hours prior to use.

Plug the refrigerator in a 110V~ socket exclusively for the unit. After the refrigerator is running, test the air suction to confirm it is sufficiently cold. Then you may put food inside the unit. Make sure the food product is already cooled before placing it in the display case. The unit should not be used to cool food products.

### DIGITAL TEMPERATURE CONTROLLER

The digital temperature controller is easy to operate and controls the compressor.

- The main functions are: Temperature display, temperature control, manual control, automatic defrost, light control, value storing, self-testing and parameter locking.

Digital Controller Operation:

1. Set Temperature:  
Press **SET** and the set temperature is displayed.  
Press ▲ or ▼ button to modify and store the displayed value.



Press **SET** to exit the adjustment and display the cold-room temperature.

2. If no buttons are pressed within 10 seconds, the cold-room temperature will be displayed.
3. Illumination:  
Press the light button, it lights. Press the light button again, the light turns off.
4. Manual start/stop defrost:  
Press the light button and hold for 6 seconds to defrost or stop defrost.
5. Refrigerant LED:  
During refrigeration, the LED is on. When the cold-room temperature is consistent, the LED is off. During the delay start, the LED flashes.
6. Defrost LED:  
During defrosting, the LED is on. When it stops defrosting, the LED is off. During the delay display of defrost, the LED flashes.
7. Digital Controller Reset:  
When the display shows “disorder”, press ▼ button for 2 seconds until buzzer rings, quickly press ▲ button for 6 seconds until the buzzer rings again. The display will flash for 3 seconds and it will be restored to the factory setting.

## SWITCHING OPERATION

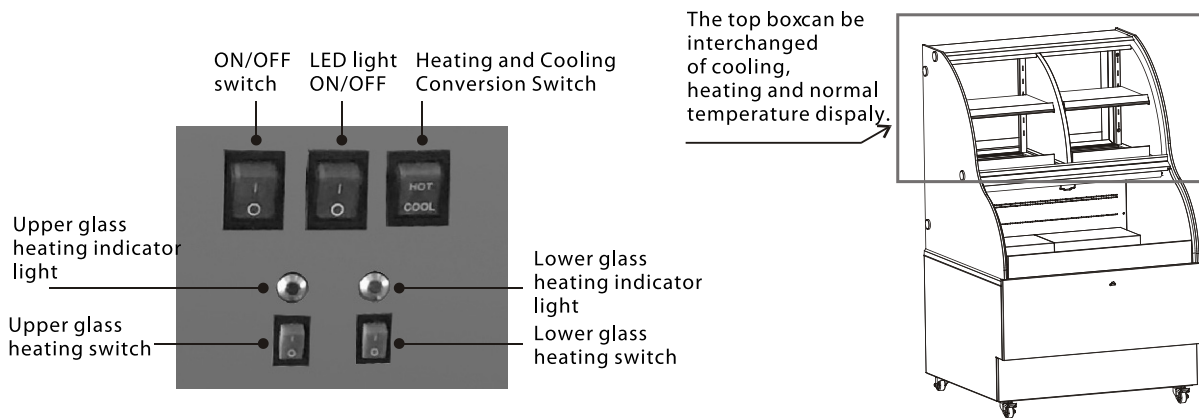

1. ON/OFF switch, Press it to “I”, the machine start working, Press it to “O”, the machine stop working.
2. LED light ON/OFF, press it to “I”, LED is on, press it to “O”, LED is off.
3. Heating and Cooling Conversion Switch. Press “COOL”, air vent open, the top box is converted to cooling. The upper and lower glass heating switch are invalid. Press “HOT”, air vent closed, the top box is converted to heating, The upper and lower glass heating switch are valid.
4. Upper and lower glass heating switch. Press it to “I” heating is working, Indicator light is on. Press it to “O” heating stop working, indicator light is off.

## CAUTION

- Reducing the frequency of opening the refrigerator door will keep more cold air inside the refrigerator.
- Do not block air suction or outlet. Air must continue circulating to increase refrigeration capability.
- Do not over fill or over stock the refrigerator, as it will influence the cooling effect. Adjust the rack height for proper food storage.

# Operation

---

- Cool hot food down to room temperature before storing it in the refrigerator.
- Try to reduce open times and keep refrigerator cold and closed, if power is ever off. Only allow a skilled service individual with proper tools to repair damaged power cables. Never touch compressor, as it can result in injury.
- If supply cord is damaged, it must be replaced by the manufacturer, its service agent, or similarly qualified persons in order to avoid a hazard.
- This appliance is not intended for use by persons (including children) with reduced physical, sensory or mental capabilities, or lack of experience and knowledge, unless they have been given supervision or instruction concerning use of the appliance by a person responsible for their safety.
- Children should be supervised to ensure that they do not play with the appliance.

**WARNING:** Keep ventilation openings, in the appliance enclosure or in the built-in structure, clear of obstruction.

**WARNING:** Do not use mechanical devices of other means to accelerate the defrosting process, other than those recommended by the manufacturer.

**WARNING:** Do not damage the refrigerant circuit.

**WARNING:** Do not use electrical appliances inside the food storage compartments of the appliance, unless they are of the type recommended by the manufacturer.



**CAUTION:** Risk of fire. The height of the triangle in the symbol should be at least 15mm.

# Maintenance

---

Keep the refrigerator clean and perform periodical maintenance as necessary. Always unplug the socket before maintenance. Never use a damaged plug or loose socket in order to prevent from electric shock or short circuit. Never flush the refrigerator. Never use alkali detergent, soap, gasoline, acetone or brush.

1. Clean outside:  
Dip soft cloth in neutral detergent (tableware detergent) to clean the outside of the refrigerator and then wipe it with dry soft cloth.
2. Clean inside:  
Take rack out for cleaning with water. Use soft cloth to wipe the box.
3. Shut down refrigerator for a long time:  
Take all food out and unplug the wall socket. Clean both inside and outside of the refrigerator thoroughly and open the door for sufficient dry. The glass breaks easily. Keep the glass far from children.
4. Replacement of lamp in the light box:  
If the LED lamp is damaged, it must be replaced by the manufacturer, or its service agent.

# Troubleshooting

## ERROR CODES

Fault Code	Causes	Solutions
EE1	Open circuit or short circuit of temperature probe.	Check if the plug on mainboard is loosened or not, or change temperature probe.
EE2	Open circuit or short circuit of defrosting probe.	Check if the plug on mainboard is loosened or not, or change defrosting probe.
EE3	Open circuit or short circuit of overheating probe.	Check if the plug on mainboard is loosened or not, or change overheating probe.
EE4	Overheating probe starts protecting program (58°C / 136.4°F)	Too much dust on condenser, clean the condenser.
		Condenser motor stops working, repair or change the motor.
		The unit is too close to the wall, keep product at least 50cm from the wall.
		Ambient temperature is too high, ensure the ambient temperature stays between the specified range.

## GENERAL TROUBLESHOOTING

Problem	Causes	Solutions
Strange noise under the bottom shelf.	Fan blade broken.	Power off and fix the blade.
Not refrigerating in spite of normal operation.	Unit is off.	Power on.
	Melting process.	Stop the melting process.
	Refrigerant leaking.	Patch the leak and refill refrigerant.
	Unit failure.	Call Omcan.
Weak air from air curtain, and higher cabinet temperature.	Evaporator blocked by frost.	Increase melting frequency.
	Inside fan damaged.	Replace the fan.
	Too low set point of temperature controller.	Adjust the set point.
	Vent blocked by storage.	Remove the storage.
Normal air curtain, but higher cabinet temperature.	Insufficient refrigerant.	Refill the refrigerant.
	Too high set point of temperature controllers.	Adjust the set point for the temperature controller.
	The wind curtain disturbed by strong air flow.	Removing the disturbing factors.
	Ambient temperature or humidity beyond standards.	Improve the conditions.

# Troubleshooting

---

Melting water overflown.	Heating pipe for melting water damaged.	Replace the heating pipe.
	Water level controller failure.	Replace the water level controller.
	Ambient temperature or humidity beyond standards.	Improve the conditions.
Normal air curtain, but periodical fluctuation of cabinet temperature.	Condenser contaminated.	Clean the condenser.
	Poor venting of the unit.	Improve the venting conditions.
	Heat protection of compressor failure.	Replace the heat protection.
	Capillary is blocked by ice.	Replace the drying filter.
	Temperature controller failure.	Replace the temperature controller.

The following situations are not problems:

1. The murmur of water is heard when the refrigerator is working. This is normal as the coolant is circulating in the system.
2. During wet season, condensation may be found on the outside of the refrigerator. This is not a problem, this is caused by high humidity. Simply use a cloth to wipe it.

# Parts Breakdown

Model RS-CN-0468 47277

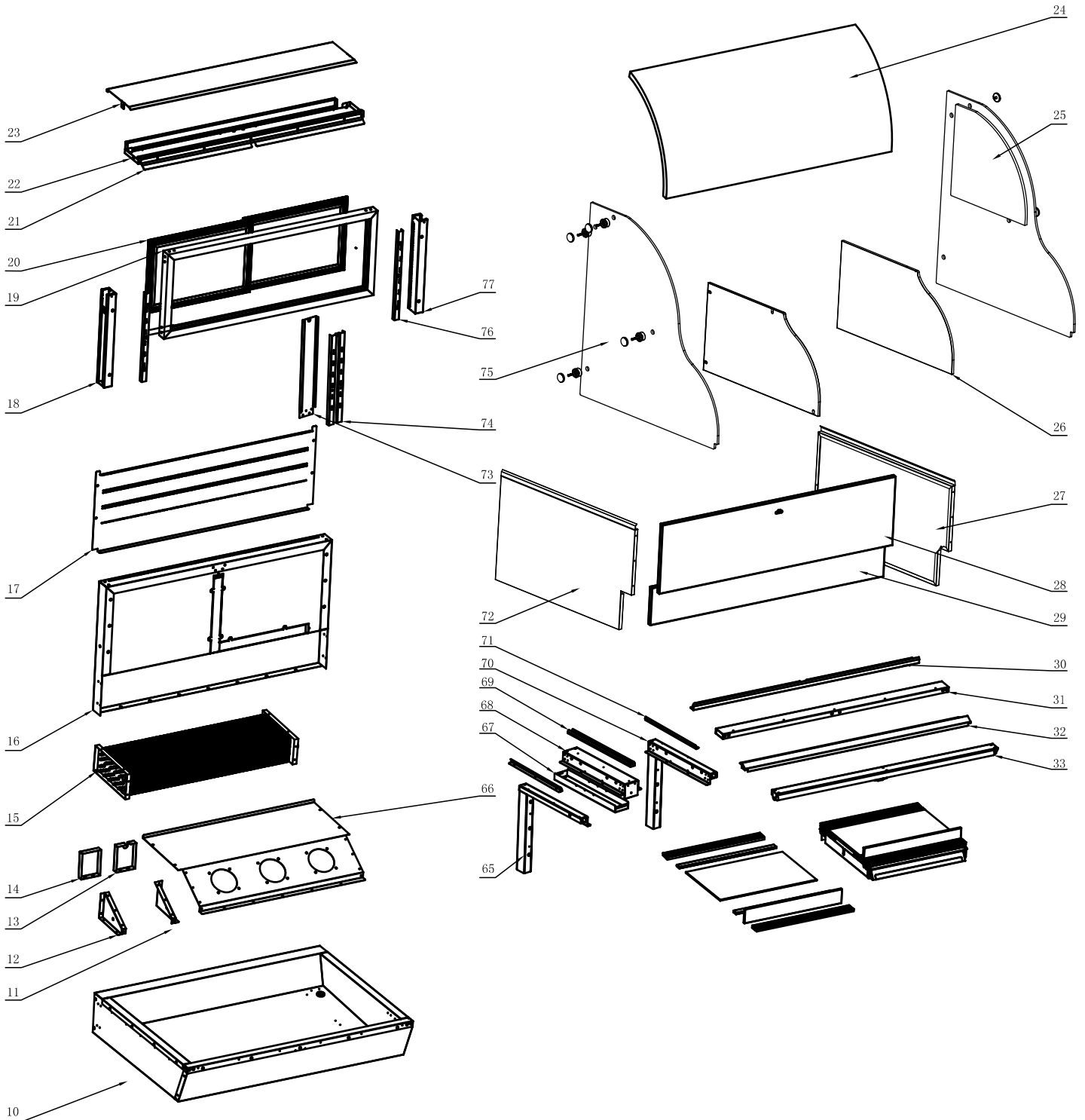

# Parts Breakdown

Model RS-CN-0468 47277

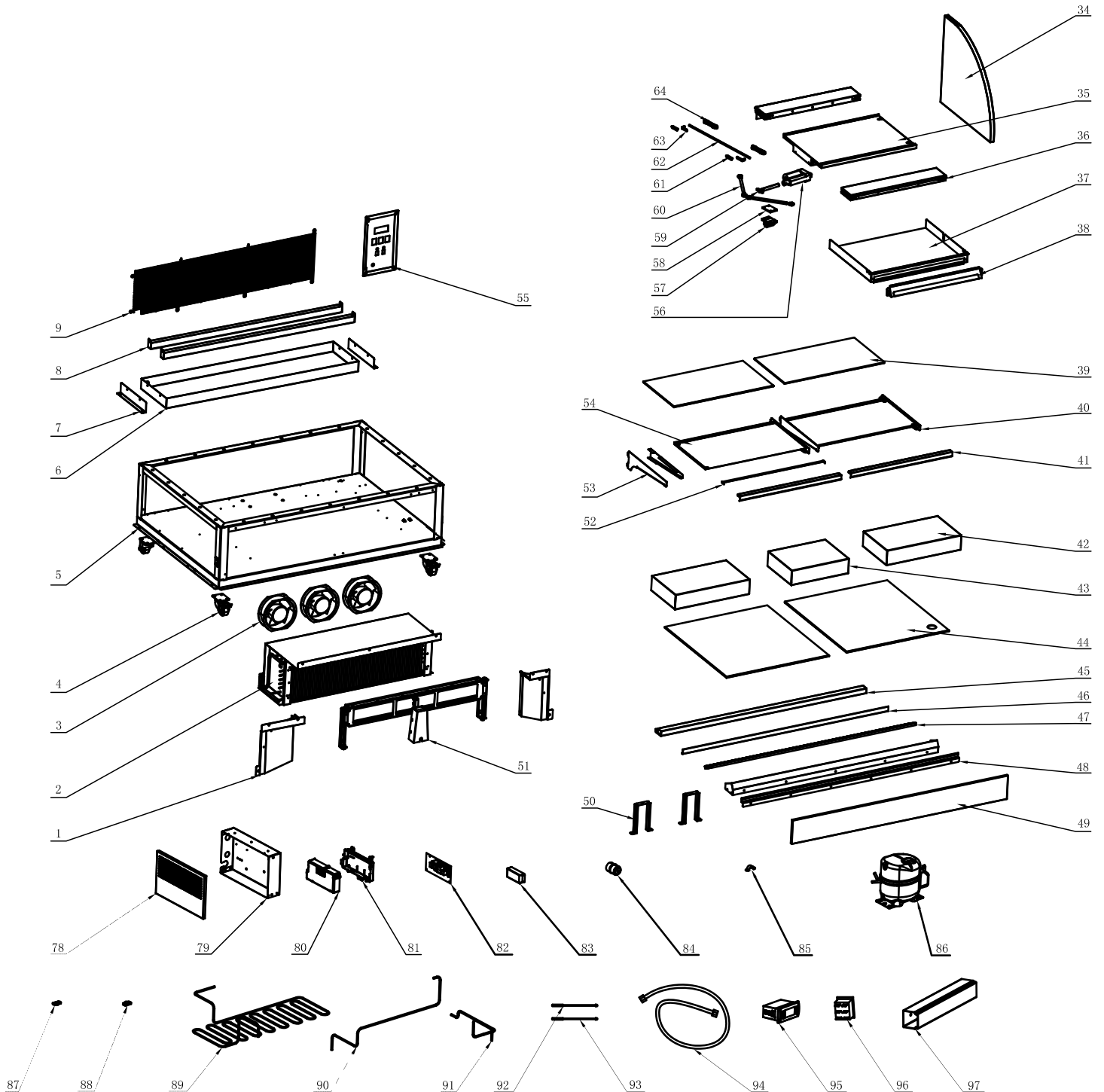

# Parts Breakdown

## Model RS-CN-0468 47277

Item No.	Description	Position	Item No.	Description	Position	Item No.	Description	Position
AI267	Condenser Air Guide Cover Left for 47277	1	AI114	Middle Partition Left for 47277	34	AI111	Middle Glass Strip for 47277	69
AI268	Condenser for 47277	2	AI289	Tray Assembly Left for 47277	35	AI085	Right Fixing Support Assembly for 47277	70
68396	Motor for 47277	3	AI290	Isolation Block Assembly for 47277	36	AI084	Strip of Top Side Glass for 47277	71
AI054	Caster for 47277	4	AI291	Isolation Board Left for 47277	37	AI064	Left Frame Assembly for 47277	72
AI269	Bottom Frame (Welded Assembly) for 47277	5	AI292	Air Guide Cover Assembly for 47277	38	AI117	Middle Pole of Shelf Back for 47277	73
AI270	Welding Assembly of High Pressure Tube for 47277	6	AI293	Shelf Glass - Heating Film for 47277	39	AI116	Middle Pole of Shelf Front for 47277	74
AI051	Fixing Support of High Pressure Tube for 47277	7	AI077	Connection Panel of Right Shelf for 47277	40	AI065	Left Side Glass for 47277	75
AI271	Pressure Board of High Pressure Tube for 47277	8	AI294	Left and Right Front Board of Shelf for 47277	41	AI074	Right Pole for Shelf for 47277	76
AI272	Back Net for 47277	9	AI092	Block Big for 47277	42	AI073	Door Frame Right Assembly for 47277	77
AI273	Base Foam of Evaporator for 47277	10	AI295	Block Small for 47277	43	AI121	Wiring Box Cover for 47277	78
AI059	Right Board of Evaporator Motor Cover for 47277	11	AI296	Flat Glass for 47277	44	AI122	Wiring Box for 47277	79
AI058	Left Board of Evaporator Motor Cover for 47277	12	AI297	Wind Screen for Air In for 47277	45	60594	Cover of Circuit Board Box for 47277	80
AI274	Evaporator Right Block for 47277	13	AI298	Cross Shield Board for Air In for 47277	46	61167	Circuit Board Box for 47277	81
AI275	Evaporator Left Block for 47277	14	AI299	Bottom Ventilation Shield Board for 47277	47	AI123	Main Board for 47277	82
AI276	Evaporator for 47277	15	AI300	Fixing Panel of Front Glass Deflector for 47277	48	67652	LED Transformer for 47277	83
AI277	Back Foam for 47277	16	AI301	Front Wind Screen for 47277	49	61224	Dry Filter for 47277	84
AI278	Ventilation Board for 47277	17	AI099	Reinforcement Board for Air In for 47277	50	60669	Pipe Clamp for 47277	85
AI115	Left Door Frame Assembly for 47277	18	AI302	Fixing Board for Shelf LED for 47277	52	AI124	Compressor for 47277	86
AI279	Top Glass Strip for 47277	21	AI113	Left Shelf Connection Panel for 47277	53	61246	Wire Clip Holder for 47277	87
AI280	Door Frame Top for 47277	22	AI303	Left Panel of Shelf for 47277	54	66095	Wire Clip Cover for 47277	88
AI281	Top Ceiling Board for 47277	23	AI112	Switch Panel for 47277	55	AI307	High Pressure Evaporator Tube for 47277	89
AI282	Curved Glass for 47277	24	AI105	Electrical Pushing Lever for 47277	56	AI126	Connection Pipe for 47277	90
AI120	Right Side Glass for 47277	25	AI101	Fixing Seat for 47277	57	AI308	Connection Pipe for 47277	91
AI119	Right Side Interior Panel for 47277	26	AI102	Seat Pad for 47277	58	68353	Temperature Sensor for 47277	92
AI283	Right Frame Assembly for 47277	27	AI107	Fixing Panel for Air In for 47277	61	67674	Compressor Protect Probe for 47277	93
AI284	Front Top Frame for 47277	28	AI304	Pulley Rail Pin for 47277	62	60668	Drain Pipe for 47277	94
AI285	Front Bottom Frame for 47277	29	AI106	Positioning Block for Pulley Rail for 47277	63	67648	Temperature Display for 47277	95
AI286	Front Glass Strip for 47277	30	AI305	Left Fixing Support Assembly for 47277	65	60119	Switch for 47277	96
AI287	Front Fixing Support Assembly for 47277	31	AI306	Evaporator Motor Cover for 47277	66	60590	PVC Trucking for 47277	97
AI288	Front Shield Board of Top Shelf for 47277	32	AI109	Middle Fixing Support Bottom for 47277	67			
66104	Curtain for 47277	33	AI110	Middle Fixing Support for 47277	68			

# Electrical Schematics

Model RS-CN-0468 47277

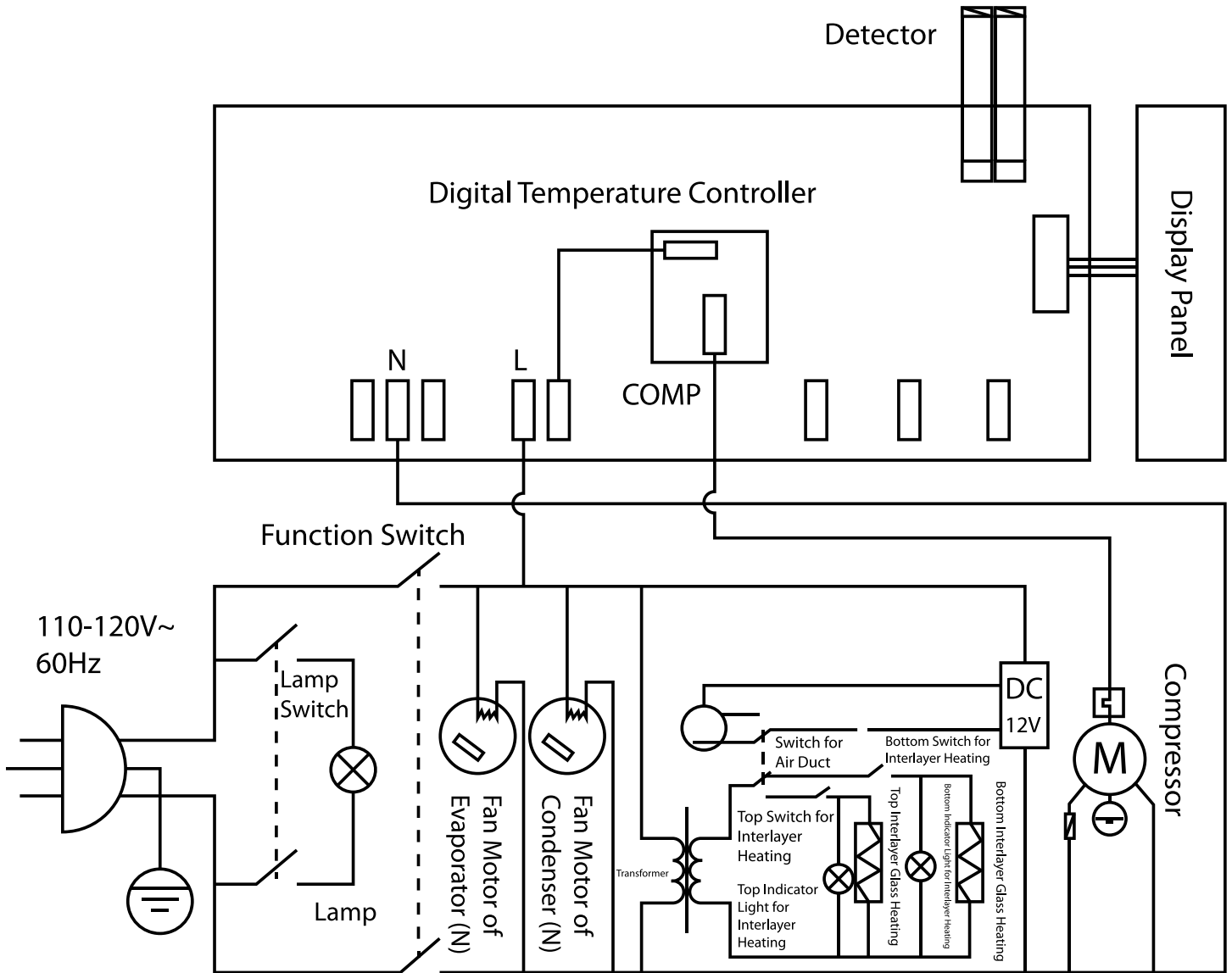









# Warranty Registration

Thank you for purchasing an Omcan product. To register your warranty for this product, complete the information below, tear off the card at the perforation and then send to the address specified below. You can also register online by visiting:

Merci d'avoir acheté un produit Omcan. Pour enregistrer votre garantie pour ce produit, complétez les informations ci-dessous, détachez la carte au niveau de la perforation, puis l'envoyer à l'adresse spécifiée ci-dessous. Vous pouvez également vous inscrire en ligne en visitant:

Gracias por comprar un producto Omcan usted. Para registrar su garantía para este producto, complete la información a continuación, cortar la tarjeta en la perforación y luego enviarlo a la dirección indicada a continuación. También puede registrarse en línea en:

<https://omcan.com/warranty-registration/>

For mailing in Canada

Pour postale au Canada

Por correo en Canadá

**OMCAN**

PRODUCT WARRANTY REGISTRATION

3115 Pepper Mill Court,

Mississauga, Ontario

Canada, L5L 4X5

For mailing in the US

Pour diffusion aux États-Unis

Por correo en los EE.UU.

**OMCAN**

PRODUCT WARRANTY REGISTRATION

4450 Witmer Industrial Estates, Unit 4,

Niagara Falls, New York

USA, 14305

*or email to: [service@omcan.com](mailto:service@omcan.com)*



Purchaser's Information

Name: \_\_\_\_\_

Address: \_\_\_\_\_

City: \_\_\_\_\_ Province or State: \_\_\_\_\_ Postal or Zip: \_\_\_\_\_

Country: \_\_\_\_\_

Dealer from which Purchased: \_\_\_\_\_

Dealer City: \_\_\_\_\_ Dealer Province or State: \_\_\_\_\_

Invoice: \_\_\_\_\_

Model Name: \_\_\_\_\_ Model Number: \_\_\_\_\_

Machine Description: \_\_\_\_\_

Date of Purchase (MM/DD/YYYY): \_\_\_\_\_

Would you like to extend the warranty?  Yes  No

Company Name: \_\_\_\_\_

Telephone: \_\_\_\_\_

Email Address: \_\_\_\_\_

Type of Company:

Restaurant  Bakery  Deli

Butcher  Supermarket  Caterer

Institution (*specify*): \_\_\_\_\_

Other (*specify*): \_\_\_\_\_

Serial Number: \_\_\_\_\_

Date of Installation (MM/DD/YYYY): \_\_\_\_\_

**Thank you for choosing Omcan | Merci d'avoir choisi Omcan | Gracias por elegir Omcan**



Since 1951 Omcan has grown to become a leading distributor of equipment and supplies to the North American food service industry. Our success over these many years can be attributed to our commitment to strengthen and develop new and existing relationships with our valued customers and manufacturers. Today with partners in North America, Europe, Asia and South America, we continually work to improve and grow the company. We strive to offer customers exceptional value through our qualified local sales and service representatives who provide convenient access to over 6,500 globally sourced products.

---

Depuis 1951 Omcan a grandi pour devenir un des “leaders” de la distribution des équipements et matériel pour l’industrie des services alimentaires en Amérique du Nord. Notre succès au cours de ces nombreuses années peut être attribué à notre engagement à renforcer et à développer de nouvelles et existantes relations avec nos clients et les fabricants de valeur. Aujourd’hui avec des partenaires en Amérique du Nord, Europe, Asie et Amérique du Sud, nous travaillons continuellement à améliorer et développer l’entreprise. Nous nous efforçons d’offrir à nos clients une valeur exceptionnelle grâce à nos ventes locales qualifiées et des représentants de service qui offrent un accès facile à plus de 6500 produits provenant du monde entier.

---

Desde 1951 Omcan ha crecido hasta convertirse en un líder en la distribución de equipos y suministros de alimentos en América del Norte industria de servicios. Nuestro éxito en estos años se puede atribuir a nuestro compromiso de fortalecer y desarrollar nuevas relaciones existentes con nuestros valiosos clientes y fabricantes. Hoy con socios de América del Norte, Europa, Asia y América del Sur, que trabajan continuamente para mejorar y crecer la empresa. Nos esforzamos por ofrecer a nuestros clientes valor excepcional a través de nuestro local de ventas y representantes de los servicios que proporcionan un fácil acceso a más de 6,500 productos con origen a nivel mundial.

