



Refrigerated Showcases
Models RS-CN-0530, 0700, 1050
Items 43459, 41469, 43460
Instruction Manual



Revised - 03/01/2021



Toll Free: 1-800-465-0234
Fax: 905-607-0234
Email: service@omcan.com
www.omcan.com

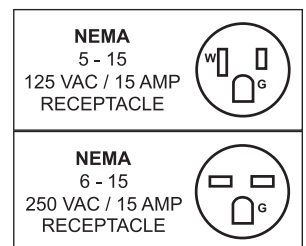

Table of Contents

Model RS-CN-0530 / Model RS-CN-0700 / Model RS-CN-1050

Section	Page
Disclaimer -----	3
General Information -----	4 - 5
Safety and Warranty -----	5 - 7
Technical Specifications -----	7
Operation -----	8 - 9
Maintenance -----	9
Troubleshooting -----	9 - 10
Parts Breakdown -----	11 - 16
Electrical Schematics -----	17 - 19
Notes -----	20 - 22
Warranty Registration -----	23

Disclaimer

OMCAN IS NOT RESPONSIBLE FOR ANY DAMAGES DUE TO WATER LEAKS. WARRANTY FOR WATER LEAKS IS VOID IF THE AMBIENT ROOM TEMPERATURE EXCEEDS 75°F AND 55% RELATIVE HUMIDITY, AND THE APPLIANCE DRAIN IS NOT CONNECTED DIRECTLY TO A FLOOR DRAIN.

General Information

Omcan Manufacturing and Distributing Company Inc., Food Machinery of America, Inc. dba Omcan and Omcan Inc. are not responsible for any harm or injury caused due to any person's improper or negligent use of this equipment. The product shall only be operated by someone over the age of 18, of sound mind, and not under the influence of any drugs or alcohol, who has been trained in the correct operation of this machine, and is wearing authorized, proper safety clothing. Any modification to the machine voids any warranty, and may cause harm to individuals using the machine or in the vicinity of the machine while in operation.

CHECK PACKAGE UPON ARRIVAL

Upon receipt of an Omcan shipment please inspect for external damage. If no damage is evident on the external packaging, open carton to ensure all ordered items are within the box, and there is no concealed damage to the machine. If the package has suffered rough handling, bumps or damage (visible or concealed), please note it on the bill of lading before accepting the delivery and contact Omcan within 24 hours, so we may initiate a claim with the carrier. A detailed report on the extent of the damage caused to the machine must be filled out within three days, from the delivery date shown in the shipping documents. Omcan has no recourse for damaged products that were shipped collect or third party.

Before operating any equipment, always read and familiarize yourself with all operation and safety instructions.

Omcan would like to thank you for purchasing this machine. It's of the utmost importance to save these instructions for future reference. Also save the original box and packaging for shipping the equipment if servicing or returning of the machine is required.

Omcan Fabrication et distribution Compañie Limité et Food Machinery d'Amérique, dba Omcan et Omcan Inc. ne sont pas responsables de tout dommage ou blessure causé du fait que toute personne ait utilisé cet équipement de façon irrégulière. Le produit ne doit être exploité que par quelqu'un de plus de 18 ans, saine d'esprit, et pas sous l'influence d'une drogue ou d'alcool, qui a été formé pour utiliser cette machine correctement, et est vêtu de vêtements de sécurité approprié. Toute modification de la machine annule toute garantie, et peut causer un préjudice à des personnes utilisant la machine ou des personnes à proximité de la machine pendant son fonctionnement.

VÉRIFIEZ LE COLIS DÈS RÉCEPTION

Dès réception d'une expédition d'Omcan veuillez inspecter pour dommages externes. Si aucun dommage n'est visible sur l'emballage externe, ouvrez le carton afin de s'assurer que tous les éléments commandés sont dans la boîte, et il n'y a aucun dommage dissimulé à la machine. Si le colis n'a subi aucune mauvaises manipulations, de bosses ou de dommages (visible ou cachée), notez-le sur le bond de livraison avant d'accepter la livraison et contactez Omcan dans les 24 heures qui suivent, pour que nous puissions engager une réclamation auprès du transporteur. Un rapport détaillé sur l'étendue des dommages causés à la machine doit être rempli dans un délai de trois jours, à compter de la date de livraison indiquée dans les documents d'expédition. Omcan n'a aucun droit de recours pour les produits endommagés qui ont été expédiés ou cueilli par un tiers transporteur.



General Information

Avant d'utiliser n'importe quel équipement, toujours lire et vous familiariser avec toutes les opérations et les consignes de sécurité.

Omcan voudrais vous remercier d'avoir choisi cette machine. Il est primordial de conserver ces instructions pour une référence ultérieure. Également conservez la boîte originale et l'emballage pour l'expédition de l'équipement si l'entretien ou le retour de la machine est nécessaire.

Omcan Empresa De Fabricacion Y Distribucion Inc. Y Maquinaria De Alimentos De America, Inc. dba Omcan y Omcan Inc. no son responsables de ningun daño o perjuicio causado por cualquier persona inadecuada o el uso descuidado de este equipo. El producto solo podra ser operado por una persona mayor de 18 años, en su sano juicio y no bajo alguna influencia de droga o alcohol, y que este ha sido entrenado en el correcto funcionamiento de esta máquina, y ésta usando ropa apropiada y autorizada. Cualquier modificación a la máquina anula la garantía y puede causar daños a las personas usando la máquina mientras esta en el funcionamiento.

REVISE EL PAQUETE A SU LLEGADA

Tras la recepcion de un envio Omcan favor inspeccionar daños externos. Si no hay daños evidentes en el empaque exterior, Habra el carton para asegurarse que todos los articulos solicitados estén dentro de la caja y no encuentre daños ocultos en la máquina. Si el paquete ha sufrido un manejo de poco cuidado, golpes o daños (visible o oculto) por favor anote en la factura antes de aceptar la entrega y contacte Omcan dentro de las 24 horas, de modo que podamos iniciar una reclamación con la compañía. Un informe detallado sobre los daños causados a la máquina debe ser llenado en el plazo de tres días, desde la fecha de entrega que se muestra en los documentos de envío. Omcan no tiene ningun recurso por productos dañados que se enviaron a recoger por terceros.

Antes de utilizar cualquier equipo, siempre lea y familiarizarse con todas las instrucciones de funcionamiento y seguridad.

Omcan le gustaría darle las gracias por la compra de esta máquina. Es de la mayor importancia para salvar estas instrucciones para futuras consultas. Además, guarda la caja original y el embalaje para el envío del equipo si servicio técnico o devolución de la máquina que se requiere.

Safety and Warranty

HANDLING AND INSTALLATION

Handle with care Unplug from the wall socket before moving. Never tilt the refrigerator over 45 degrees during handling.	Storage Always store the refrigerator in a dry place.
--	---

Safety and Warranty

<p>Sufficient space To allow for proper air circulation and increased refrigeration capabilities, the refrigerator must have at least 4"/10cm of space between wall/ceiling and the machine.</p>	<p>Proper ventilation Always place the refrigerator in an area with good ventilation. For first time use, set in location and wait at least 2 hours before plugging into wall socket.</p>
<p>Away from heat source Never place the refrigerator near any type of heat source or in direct sunlight, as it reduces refrigeration capabilities.</p>	<p>No heavy load Never put heavy items on top of the refrigerator.</p>
<p>No altercations/tampering Never tamper with or make changes to the refrigerator. Changes and add-ons should not be installed to the inside or outside of the refrigerator.</p>	<p>Stable location Unpack and place the refrigerator on flat, solid ground.</p>

PREPARATION AND POWER SUPPLY

<p>Exclusive power outlet Power supply should be 220V, single phase AC with exclusive single phase three pin outlet (250V/10A) and fuse (6A). The power outlet must be in close proximity to the ground.</p>	<p>No shared power outlets Refrigerator cable should never share the power outlet with any other appliance, as cable will overheat and may result in a fire.</p>
<p>Protect cables Extra caution should be used when handling cables, as broken or damaged cables can cause sparking and may result in a fire.</p>	<p>No water flushing Never flush the refrigerator surface. This can cause leakage, which may result in electrical damage or fire.</p>
<p>Never store flammables and explosives No explosives or flammables should be stored in, or in proximity to, the refrigerator, such as gasoline, alcohol, and adhesives.</p>	<p>No spray Never spray flammables such as paint or coating near the refrigerator. This may cause fire or malfunction.</p>
<p>After power outage After a power outage or the unplugging of the refrigerator, wait at least 5 minutes before plugging it back in.</p>	<p>No medicine Medicine should not be stored inside of the refrigerator.</p>

OMCAN IS NOT RESPONSIBLE FOR ANY DAMAGES DUE TO WATER LEAKS. WARRANTY FOR WATER LEAKS IS VOID IF THE AMBIENT ROOM TEMPERATURE EXCEEDS 75°F AND 55% RELATIVE HUMIDITY, AND THE APPLIANCE DRAIN IS NOT CONNECTED DIRECTLY TO A FLOOR DRAIN.

1 YEAR PARTS AND LABOUR WARRANTY

Within the warranty period, contact Omcan Inc. at 1-800-465-0234 to schedule an Omcan authorized service technician to repair the equipment locally.



Safety and Warranty

Unauthorized maintenance will void the warranty. Warranty covers electrical and part failures not improper use.

Please see <https://omcan.com/disclaimer> for complete info.

WARNING:

The packaging components are classified as normal solid urban waste and can therefore be disposed of without difficulty.

In any case, for suitable recycling, we suggest disposing of the products separately (differentiated waste) according to the current norms.

DO NOT DISCARD ANY PACKAGING MATERIALS IN THE ENVIRONMENT!

Technical Specifications

Model	RS-CN-0530	RS-CN-0700	RS-CN-1050
Rated Input Power	1340 W	2650 W	1960 W
Capacity	530 L / 18.7 cu.ft.	700 L / 24.7 cu.ft.	1050 L / 37 cu.ft.
Electrical	120V / 60Hz / 1	220V / 60Hz / 1	
Lamp Power	1.44 W x 6 (LED)		
Shelf Load Capacity	55 lbs. / 25 kgs.	66 lbs. / 30 kgs.	110 lbs. / 50 kgs.
Temperature Range	2 - 10°C / 35.6 - 50°F		
Max Ambient Temp Rating	32°C / 90°F		
Refrigerant and Injection	R404a (960g)	R404a (1250g)	R404a (1300g)
Type of Climate	3	6	3
Rated Current	11.8A	12A	9.6A
Weight	306 lbs. / 139 kgs.	418 lbs. / 190 kgs.	533.5 lbs. / 242 kgs.
Packaging Weight	352.7 lbs. / 160 kgs.	469.6 lbs. / 213 kgs.	621.7 lbs. / 282 kgs.
Dimensions	36" x 30.1" x 81.5" 915 x 765 x 2070mm	48" x 30.1" x 81.5" 1220 x 765 x 2070mm	72" x 30.1" x 81.5" 1829 x 765 x 2070mm
Packaging Dimensions	40" x 33.6" x 84" 1015 x 853 x 2130mm	52" x 33.6" x 84" 1320 x 853 x 2130mm	76" x 33.6" x 84" 1930 x 850 x 2130mm
Item Number	43459	41469	43460

Operation

BEFORE USE

- Plug refrigerator into the 220V exclusive socket.
- After the refrigerator is running, confirm that air suction/filtration is in working order and that it is sufficiently cold. After checking to make sure the refrigerator is working properly, it may be used.

DIGITAL TEMPERATURE CONTROLLER

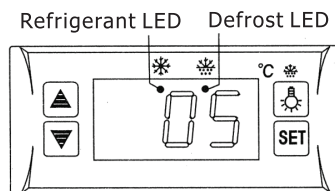

FEATURES OF FUNCTION

- Small, integrated digital controller, which is applicable to the compressor of 1 Hp. Located behind the front grill.
- Main functions are: Temperature Display/Temperature Control/Manual-Automatic /Light Control/Value Storing/Self-Testing/Parameter Locking.

FRONT PANEL OPERATION

1. Set temperature: Press **SET** button; set temperature will be displayed. Press **▲** or **▼** button to modify and store the displayed value. Press **SET** button to exit the adjustment and display the cold-room temperature.
2. If no button is pressed within 10 seconds, the cold-room temperature will be displayed.
3. Lighting: Press **☹** button to activate light in refrigerator; press again to turn off. Manual start/stop defrost: Press **☹** button and hold for 6 seconds to either defrost or to stop defrost.
4. Refrigeration LED: During refrigeration, the LED is on. When the cold room temperature is constant, the LED is off. During delay start, the LED flashes.
5. Defrost LED: During defrosting, the LED is on. When it stops defrosting, the LED is off. During the delay of defrost, the LED flashed.

CAUTION

- Never block the air outlet and suction to keep the air circulation and refrigeration capability constant.
- Do not overfill refrigerator with food, as it will influence the cooling effect. If needed, adjust the rack height for proper food storage.
- Cool down hot food to room temperature before placing inside the refrigerator.
- When power supply has been cut off, reduce opening times and maintain cool temperature in refrigerator.
- To avoid scalding, never touch the compressor.
- If the supply cord is damaged, it must be replaced by the manufacturer, its service agent, or similarly qualified persons in order to avoid hazard.

Operation

- This appliance is not intended for use by persons (including children) with reduced physical, sensory or mental capabilities, or lack of experience and knowledge, unless they have been given supervision or instruction concerning use of the appliance by a person responsible for their safety.
- Children should be supervised to ensure that they do not play with the appliance.

Maintenance

1. Cabinet Cleaning:
 - a. The product should be maintained and cleaned periodically with power supply disconnected. In cleaning, please use mild-rinsing water or non-corrosive products. Do not wash directly with water faucet.
 - b. Clean outside of unit using a soft cloth with neutral detergent, and dry with a separate soft cloth.
 - c. Clean inside racks by removing them from the unit and clean with water.
2. When shutting down unit for a long period of time, take out all food and unplug wall socket. Clean inside and outside thoroughly, and keep door open to sufficiently dry.
3. As glass breaks easily, keep far away from children.
4. Frequently observe the operation of the product. In case of any abnormal noise or smell, cut off the power supply immediately and call professionals. Do not restart the product before source of trouble is found.
5. We will not be responsible for any accidents acquired through failure to follow previous notices.

SERVICE

- To maintain good refrigeration performance, a refrigeration service person should be called periodically (at least twice a year) to clean the discharge honeycomb and remove any accumulated dirt from the condenser coil and condensate evaporator pan on self-contained models. POOR CIRCULATION OF AIR THROUGH THE CONDENSER COIL WILL RESULT IN POOR REFRIGERATION PERFORMANCE.
- Dirt accumulation inside the condensate evaporator pan will reduce the pan's capacity and affect the efficiency of the heater causing a burned out heater and an overflow of defrost water onto the store floor.

Troubleshooting

Trouble	Causes	Solutions
Strange noise under the bottom shelf.	Fan blade broken.	Power off and fix the blade.
Non-refrigerating in spite of normal operation.	Unit off.	Power on.
	Melting process.	Stop melting.
	Refrigerant leaking.	Patch the leak and refill refrigerant.
	Unit failure.	Call Omcan.

Troubleshooting

Weak air from air curtain, and higher cabinet temperature.	Evaporator blocked by frost.	Increase melting frequency.
	Inside fan damaged.	Replace the fan.
	Too low point of temperature controller.	Adjust the set point.
	Vent blocked by storage.	Remove the storage.
Normal air curtain, but higher cabinet temperature.	Insufficient refrigerant.	Refill the refrigerant.
	Too high set point of temperature controllers.	Adjust the set point for the temperature controller.
	The wind curtain disturbed by strong air flow.	Removing the disturbing factors.
	Ambient temperature or humidity beyond standards.	Improve the conditions.
Melting water overflows.	Heating pipe for melting water damaged.	Replace the heating pipe.
	Water level controller failure.	Replace the water level controller.
	Ambient temperature or humidity beyond standards.	Improve the conditions.
Normal air curtain, but periodical fluctuation of cabinet temperature.	Condenser contaminated.	Clean the condenser.
	Poor venting of the unit.	Improve the venting conditions.
	Heat protection of compressor failure.	Replace the heat protection.
	Capillary is blocked by ice.	Replace the drying filter.
	Temperature controller failure.	Replace the temperature controller.
Water leaks on floor.	Ambient room temperature exceeds 75°F and 55% relative humidity.	Connect appliance drain to floor drain.

NOTE

Following occurrences are not problems:

- The murmur of water is heard when the refrigerator is working. It is a normal occurrence as the coolant is circulating in the system.
- When the weather is damp, condensation might be found on the outside of the refrigerator. It is caused by high humidity. Simply use cloth to wipe it off.

Parts Breakdown

Model RS-CN-0530 43459

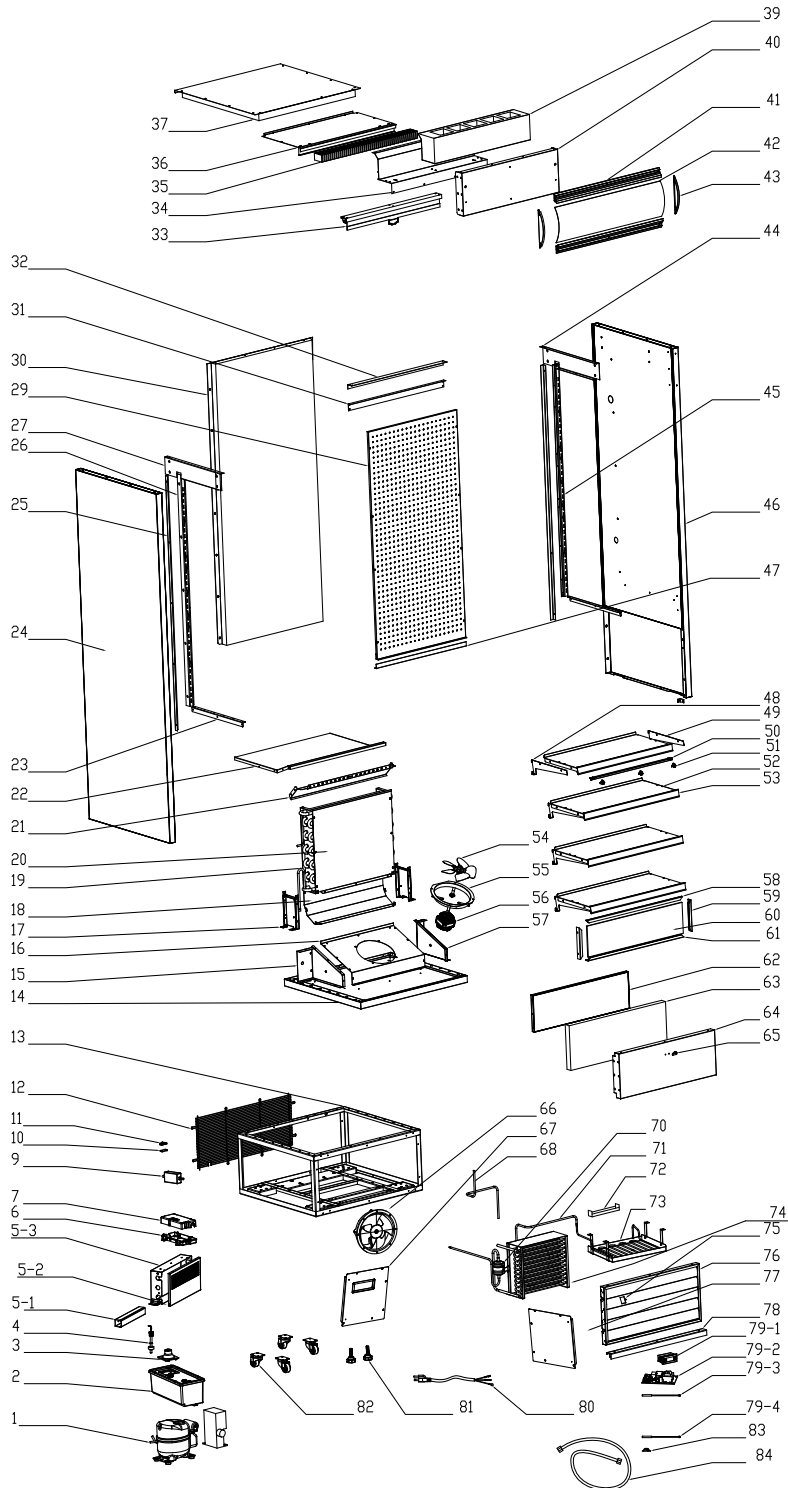

Parts Breakdown

Model RS-CN-0530 43459

Item No.	Description	Position	Item No.	Description	Position	Item No.	Description	Position
67641	Compressor for 43459	1	60612	Lower Back Plate for 43459	30	67644	Glass Deflector for 43459	60
60587	Water Receiver for 43459	2	60617	Back Foam Plate for 43459	31	60644	Decoration Strip of Glass Deflector for 43459	61
79304	Pipe for Evaporated Water for 43459	3	66096	Back Upper Crosspiece for 43459	32	60648	Lower Front Board Components for 43459	62
79305	Water Level Detector for 43459	4	66097	Night Curtain for 43459	33	60649	PE for Lower Board for 43459	63
60590	PVC Trucking for 43459	5-1	66098	Damper of Upper Air Outlet for 43459	34	60650	Lower Front Board for 43459	64
67642	Cover of Terminal Box for 43459	5-2	66099	Honeycomb Panel for 43459	35	60651	Curtain Hook for 43459	65
67643	Terminal Box for 43459	5-3	66100	Cover of Upper Air Outlet for 43459	36	79364	Condenser Fan Motor for 43459	66
61167	Circuit Board Box for 43459	6	66101	Upper Cover Plate for 43459	38	67645	Fan Guard for 43459	67
60594	Cover of Circuit Board Box for 43459	7	60698	Lining Foam for 43459	39	67646	Connection Pipe for 43459	68
60595	LED Transformer for 43459	9	66102	Upper Front Board for 43459	40	70106	Dry Filter for 43459	70
61246	Wire Clip Holder for 43459	10	60626	Lampshade Frame for 43459	41	60653	Heater for 43459	71
61245	Wire Clip Cover for 43459	11	60627	Lampshade for 43459	42	60652	Platen of Heater for 43459	72
60599	Base for 43459	12	60628	Holder of Lampshade Frame for 43459	43	67647	Tray of Heater for 43459	73
60600	Mesh Guard in Base for 43459	13	60629	Parry of Right Lining Plate for 43459	44	60658	Condenser for 43459	74
60601	Foam of Base Plate for 43459	14	60630	Right Support Pillar of Shelf for 43459	45	71514	Switch for 43459	75
60602	Left Board of Evaporator Cover for 43459	15	60631	Foam of Right Board for 43459	46	60659	Window Shade Components for 43459	76
60603	Evaporator Cover for 43459	16	60632	Back Support for Board at Air Intake for 43459	47	60662	Condenser Right Windshield for 43459	77
60604	Evaporator Holder for 43459	17	60634	Left Support of Pillar of Shelf for 43459	48	60660	Lower Front Waling for 43459	78
60605	Evaporator Ventilation Damper for 43459	18	60635	Right Support Pillar of Shelf for 43459	49	67648	Temperature Display for 43459	79-1
60606	Evaporator for 43459	19	60636	LED Strip for 43459	50	67649	Main Circuit Board for 43459	79-2
60607	Evaporator Damper for 43459	20	60637	Jump Ring of LED for 43459	51	60666	Temperature Probe for 43459	79-3
60608	Evaporator Wind Screen for 43459	21	60638	General Assembly for Shelves for 43459	52	60667	Compressor Protect Probe for 43459	79-4
60609	Plate of Air Intake for 43459	22	60639	Price Tag Holder for 43459	53	67650	Power Cord for 43459	80
60610	Parry of Lower Air Intake for 43459	23	60640	Fan Blade for 43459	54	60672	Feet for 43459	81
60611	Foam of Left Side Board for 43459	24	60641	Fan Guard for 43459	55	60561	Rear Wheels for 43459	82
60613	Dead Plate of Rear Foam for 43459	25	60931	Motor of Evaporator for 43459	56	60668	Drain Pipe for 43459	83
60614	Left Support Pillar of Shelf for 43459	26	60643	Right Board of Evaporator Cover for 43459	57	60669	Pipe Clamp for 43459	84
60615	Parry of Left Lining Plate for 43459	27	60647	Strip of Glass Deflector for 43459	58			
60616	Ventilated Board for 43459	29	60645	Strip of Glass Deflector 2 for 43459	59			

Parts Breakdown

Model RS-CN-0700 41469

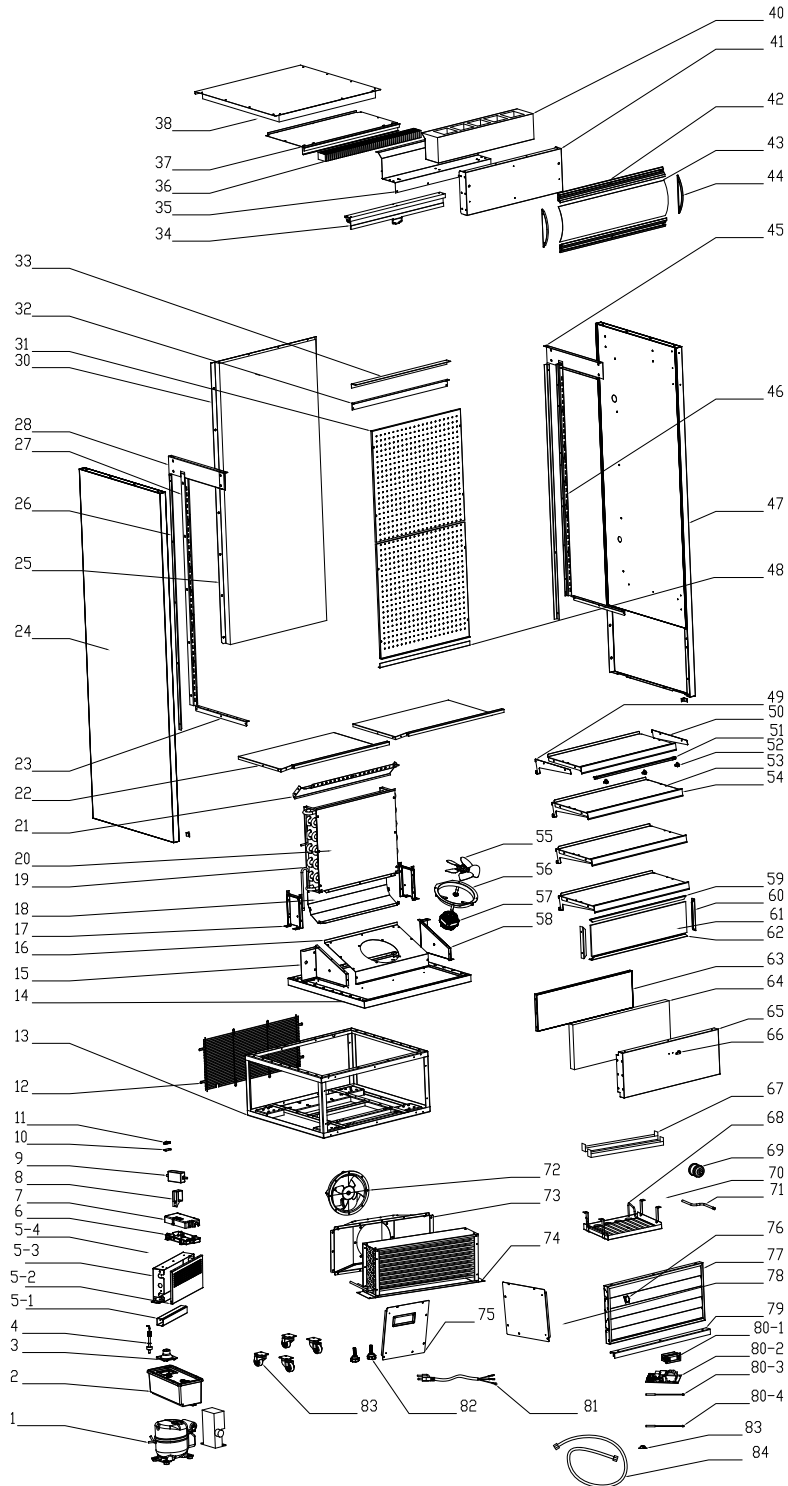

Parts Breakdown

Model RS-CN-0700 41469

Item No.	Description	Position	Item No.	Description	Position	Item No.	Description	Position
70137	Compressor for 41469	1	67658	Upper Back Plate for 41469	30	67666	Glass Deflector for 41469	61
67651	Water Receiver for 41469	2	70100	Upper or Lower Ventilated Board for 41469	31	70151	Strip of Glass Deflector for 41469	62
79304	Pipe for Evaporated Water for 41469	3	70120	Panel for Rear Foam for 41469	32	70153	Component for Front Base Panel for 41469	63
79305	Water Level Detector for 41469	4	70143	Rear Upper Strip for 41469	33	67667	PE for Lower Board for 41469	64
60590	PVC Trucking for 41469	5-1	66104	Curtain for 41469	34	70129	Front Panel of Base for 41469	65
67642	Cover of Terminal Box for 41469	5-2	67659	Damper of Upper Air Outlet for 41469	35	60651	Curtain Hook for 41469	66
67643	Terminal Box for 41469	5-3	67660	Honeycomb Panel for 41469	36	60652	Platen of Heater for 41469	67
61167	Circuit Board Box for 41469	6	70139	Upper Air Outlet for 41469	37	67668	Heater for 41469	68
60594	Cover of Circuit Board Box for 41469	7	67661	Upper Cover Plate for 41469	39	70106	Dry Filter for 41469	69
79356	LED Transformer Holder for 41469	8	60698	Lining Foam for 41469	40	60718	Tray of Heater for 41469	70
67652	LED Transformer for 41469	9	70117	Front Panel on the Top for 41469	41	60719	Joint Pipe of Dry Filter for 41469	71
60676	Wire Clip Holder for 41469	10	70141	Lampshade Frame for 41469	42	70112	Reversing Condenser Fan Motor for 41469	72
60677	Wire Clip Cover for 41469	11	70142	Lampshade for 41469	43	67669	Bracket of Condenser Motor for 41469	73
70133	Cover of Base for 41469	12	60628	Holder of Lampshade Frame for 41469	44	60728	Condenser for 41469	74
70131	Base Frame for 41469	13	60629	Parry of Right Lining Plate for 41469	45	67670	Left Panel of Condenser for 41469	75
67653	Foam of Base Plate for 41469	14	60630	Right Support Pillar of Shelf for 41469	46	71514	Switch for 41469	76
60680	Left Board of Evaporator Cover for 41469	15	60631	Foam of Right Board for 41469	47	67671	Window Shade Components for 41469	77
70154	Evaporator Cover for 41469	16	67662	Back Support for Board at Air Intake for 41469	48	67672	Right Panel of Condenser for 41469	78
60604	Evaporator Holder for 41469	17	67313	Bottom Shelf Bracket Left for 41469	49	70127	Front Bottom Strip for 41469	79
67654	Evaporator Ventilation Damper for 41469	18	67314	Bottom Shelf Bracket Right for 41469	50	67673	Temperature Display for 41469	80-1
70125	Evaporator for 41469	19	67663	LED Strip for 41469	51	60724	Main Circuit Board for 41469	80-2
67655	Evaporator Damper for 41469	20	60637	Jump Ring of LED for 41469	52	60666	Temperature Probe for 41469	80-3
67656	Evaporator Wind Screen for 41469	21	67664	General Assembly for Shelves for 41469	53	67674	Compressor Protect Probe for 41469	80-4
70132	Left/Right Air Intake for 41469	22	67665	Price Tag Holder for 41469	54	60726	Power Cord for 41469	81
60610	Parry of Lower Air Intake for 41469	23	60640	Fan Blade for 41469	55	60672	Feet for 41469	82
60611	Foam of Left Side Board for 41469	24	60641	Fan Guard for 41469	56	60561	Rear Wheels for 41469	83
67657	Lower Back Plate for 41469	25	60682	Evaporator Fan Motor for 41469	57	60669	Pipe Clamp for 41469	84
60613	Dead Plate of Rear Foam for 41469	26	60681	Right Board of Evaporator Cover for 41469	58	60668	Drain Pipe for 41469	85
60614	Left Support Pillar of Shelf for 41469	27	70149	Decorating Strip of Glass Deflector for 41469	59			
60615	Parry of Left Lining Plate for 41469	28	60645	Strip of Glass Deflector 2 for 41469	60			

Parts Breakdown

Model RS-CN-1050 43460

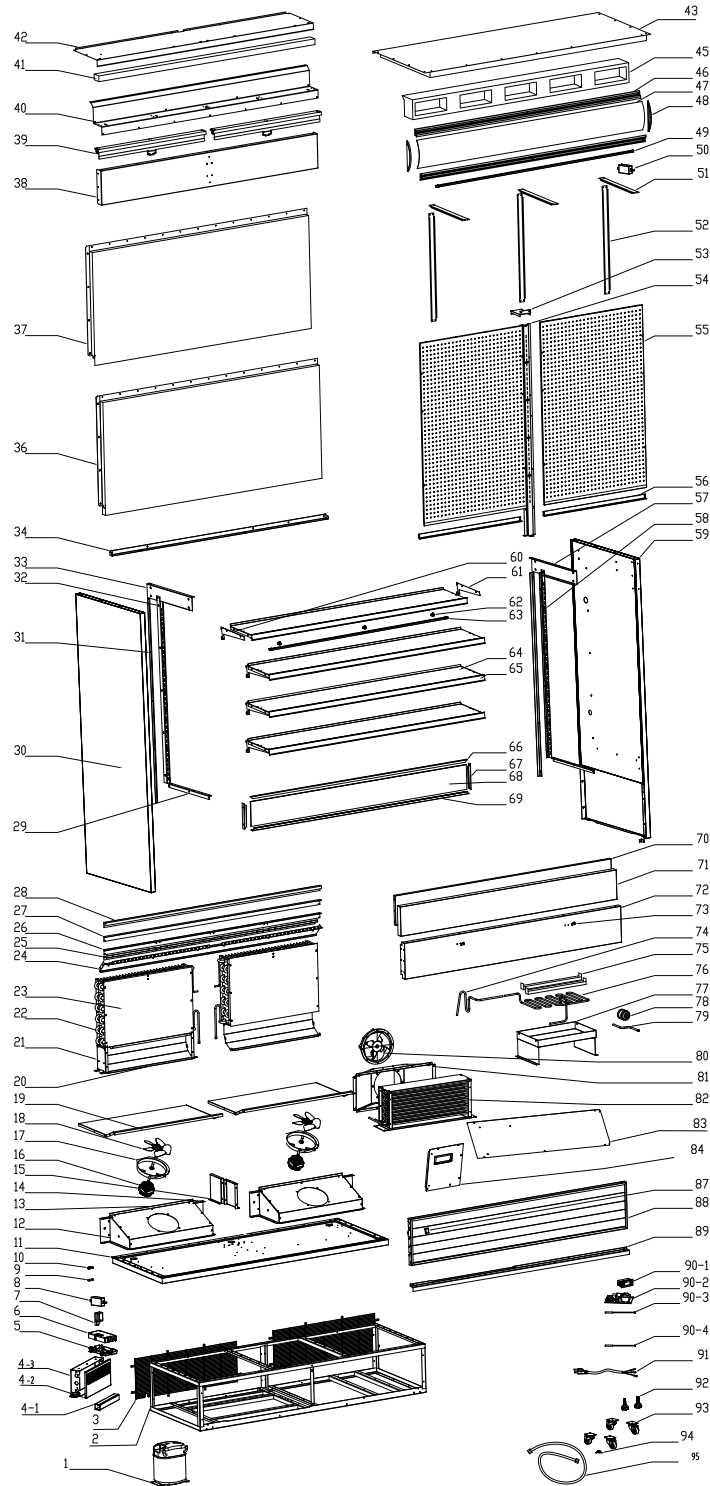

Parts Breakdown

Model RS-CN-1050 43460

Item No.	Description	Position	Item No.	Description	Position	Item No.	Description	Position
70137	Compressor for 43460	1	60613	Dead Plate of Rear Foam for 43460	31	60709	Price Tag Holder for 43460	65
60678	Mesh Guard in Base for 43460	2	60614	Left Support Pillar of Shelf for 43460	32	60710	Decorating Strip of Glass Deflector for 43460	66
60599	Base for 43460	3	60615	Parry of Left Lining Plate for 43460	33	60645	Strip of Glass Deflector 2 for 43460	67
60590	PVC Trucking for 43460	4-1	60690	Back Foam Plate for 43460	34	67686	Glass Deflector for 43460	68
67642	Cover of Terminal Box for 43460	4-2	67678	Lower Back Plate for 43460	36	60712	Strip of Glass Deflector for 43460	69
67643	Terminal Box for 43460	4-3	67679	Upper Back Plate for 43460	37	60713	Lower Front Board Components for 43460	70
61167	Circuit Board Box for 43460	5	60699	Upper Front Board for 43460	38	60714	PE for Lower Board for 43460	71
60594	Cover of Circuit Board Box for 43460	6	60692	Night Curtain for 43460	39	60715	Lower Front Board for 43460	72
79356	LED Transformer Holder for 43460	7	67680	Damper of Upper Air Outlet for 43460	40	60651	Curtain Hook for 43460	73
67652	LED Transformer for 43460	8	60694	Honeycomb Panel for 43460	41	67687	Joint Pipe of Compressor for 43460	74
60676	Wire Clip Holder for 43460	9	60695	Cover of Upper Air Outlet for 43460	42	60716	Platen of Heater for 43460	75
60677	Wire Clip Cover for 43460	10	67681	Upper Cover Plate for 43460	43	60717	Heater for 43460	76
60679	Foam of Base Plate for 43460	11	60698	Lining Foam for 43460	45	60718	Tray of Heater for 43460	77
60680	Left Board of Evaporator Cover for 43460	12	60700	Lampshade Frame for 43460	46	70106	Dry Filter for 43460	78
60603	Evaporator Cover for 43460	13	60701	Lampshade for 43460	47	60719	Joint Pipe of Dry Filter for 43460	79
60681	Right Board of Evaporator Cover for 43460	14	60628	Holder of Lampshade Frame for 43460	48	70112	Reversing Condenser Fan Motor for 43460	80
60684	Air Inlet Plate Support for 43460	15	67682	LED in Light Box for 43460	49	67669	Bracket of Condenser Motor for 43460	81
60682	Evaporator Fan Motor for 43460	16	67683	LED Transformer for 43460	50	60728	Condenser for 43460	82
79365	Fan Guard for 43460	17	60696	Upper Foam Vertical Baffle Plate for 43460	51	60723	Condenser Right Windshield for 43460	83
79366	Fan Blade for 43460	18	67684	Vertical Plate of Back Foam for 43460	52	60722	Condenser Left Windshield for 43460	84
60685	Plate of Air Intake for 43460	19	60686	After the Foam Rail Support Plate for 43460	53	71514	Switch for 43460	87
60605	Evaporator Ventilation Damper for 43460	20	60702	Space Truss Support for 43460	54	60720	Window Shade Components for 43460	88
60604	Evaporator Holder for 43460	21	60689	Ventilated Board for 43460	55	60721	Lower Front Waling for 43460	89
60606	Evaporator for 43460	22	60703	Back Support for Board at Air Intake for 43460	56	67673	Temperature Display for 43460	90-1
60607	Evaporator Damper for 43460	23	60629	Parry of Right Lining Plate for 43460	57	67688	Main Circuit Board for 43460	90-2
60683	Evaporator Wind Screen for 43460	24	60630	Right Support Pillar of Shelf for 43460	58	67689	Temperature Probe for 43460	90-3
67675	Pressing Plate of Back Foam for 43460	25	60631	Foam of Right Board for 43460	59	67690	Compressor Protect Probe for 43460	90-4
67676	Crosspiece of Back Foam for 43460	26	67313	Bottom Shelf Bracket Left for 43460	60	67691	Power Cord for 43460	91
66105	Back Upper Crosspiece for 43460	27	67314	Bottom Shelf Bracket Right for 43460	61	60672	Feet for 43460	92
67677	Thicker Crosspiece of Back Ventilated Board for 43460	28	60637	Jump Ring of LED for 43460	62	60561	Rear Wheels for 43460	93
60610	Parry of Lower Air Intake for 43460	29	67685	LED for 43460	63	60669	Pipe Clamp for 43460	94
60611	Foam of Left Side Board for 43460	30	60708	General Assembly for Shelves for 43460	64	60668	Drain Pipe for 43460	95

Electrical Schematics

Model RS-CN-0530 43459

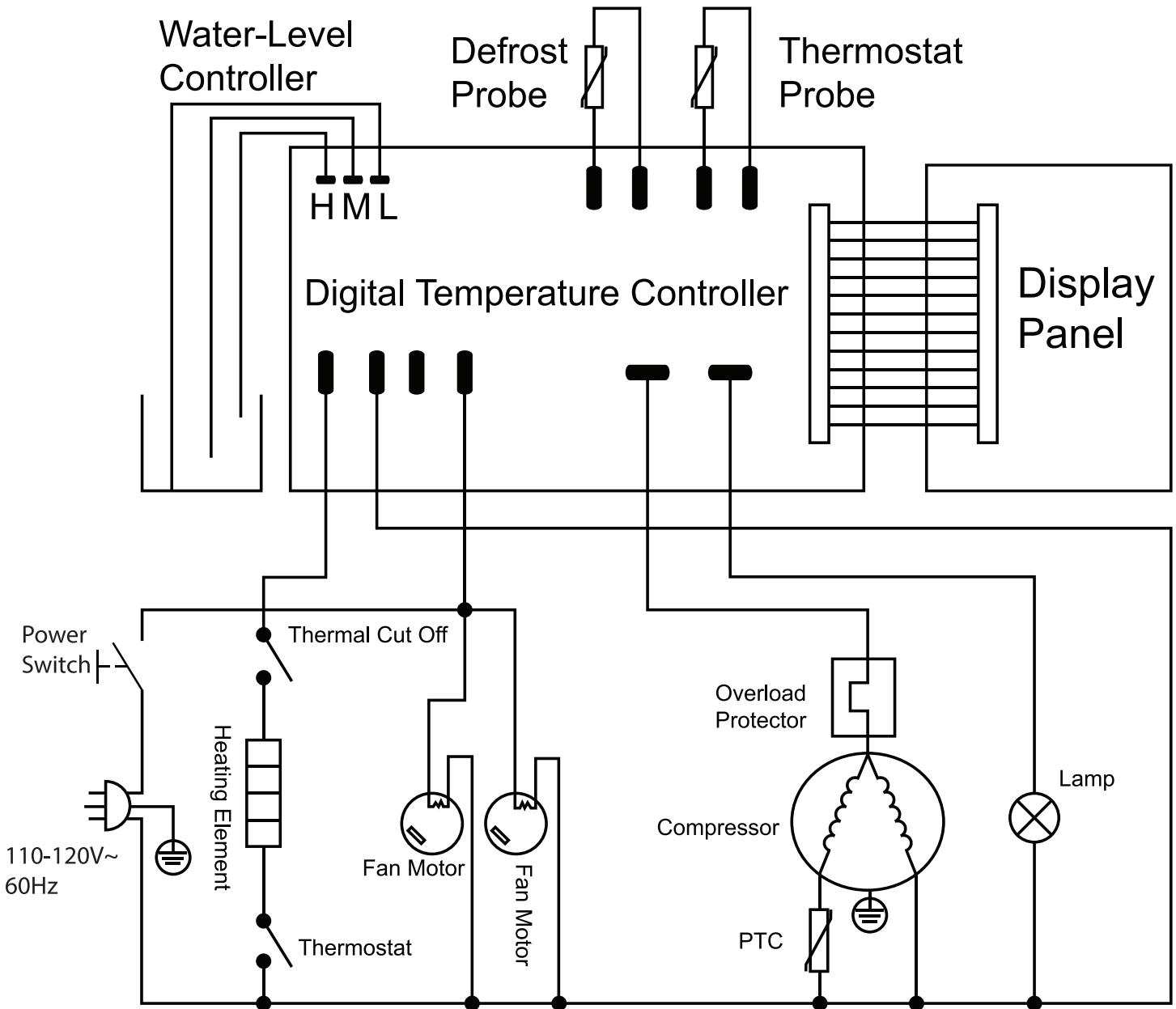

Electrical Schematics

Model RS-CN-0700 41469

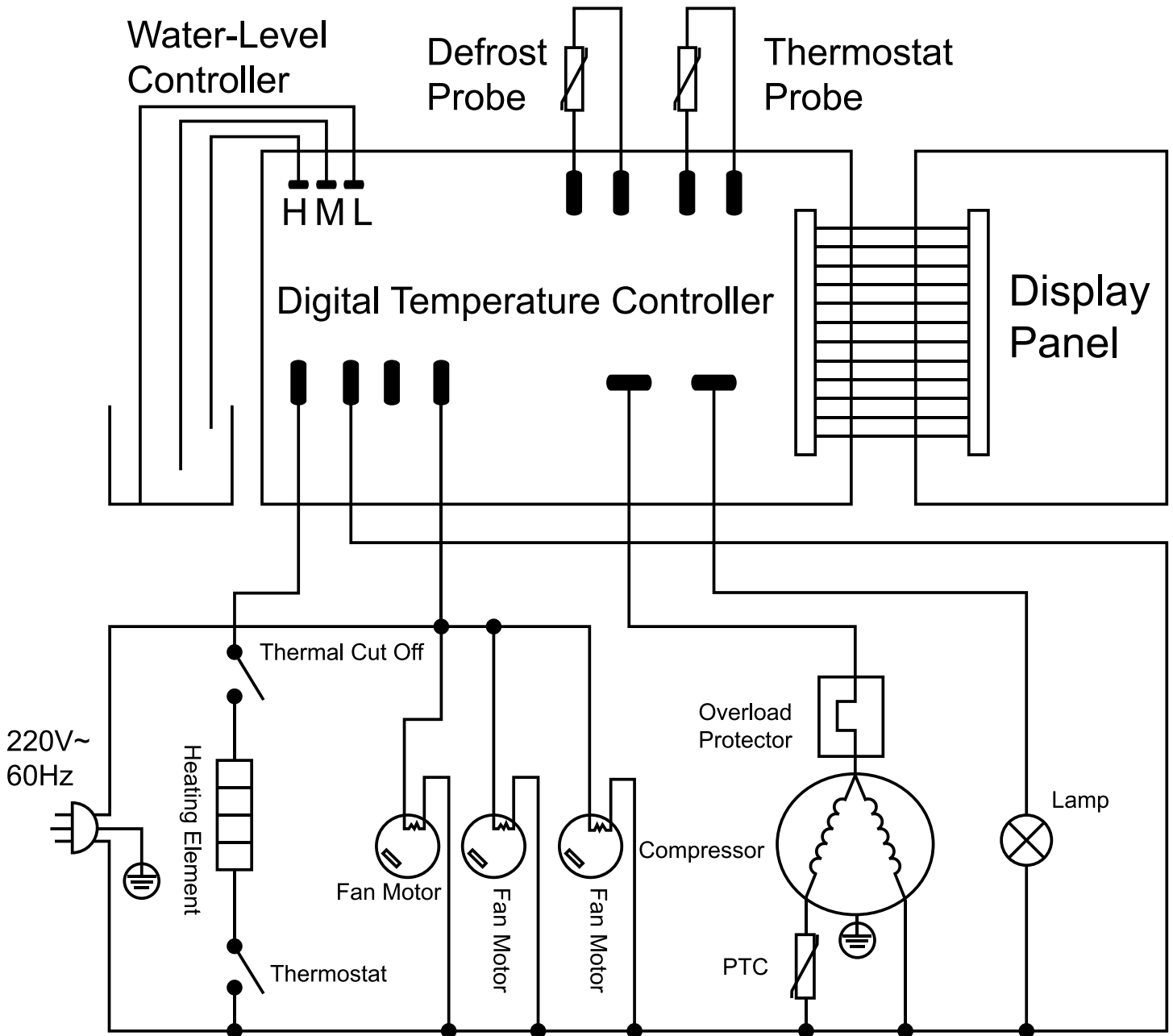

Electrical Schematics

Model RS-CN-1050 43460

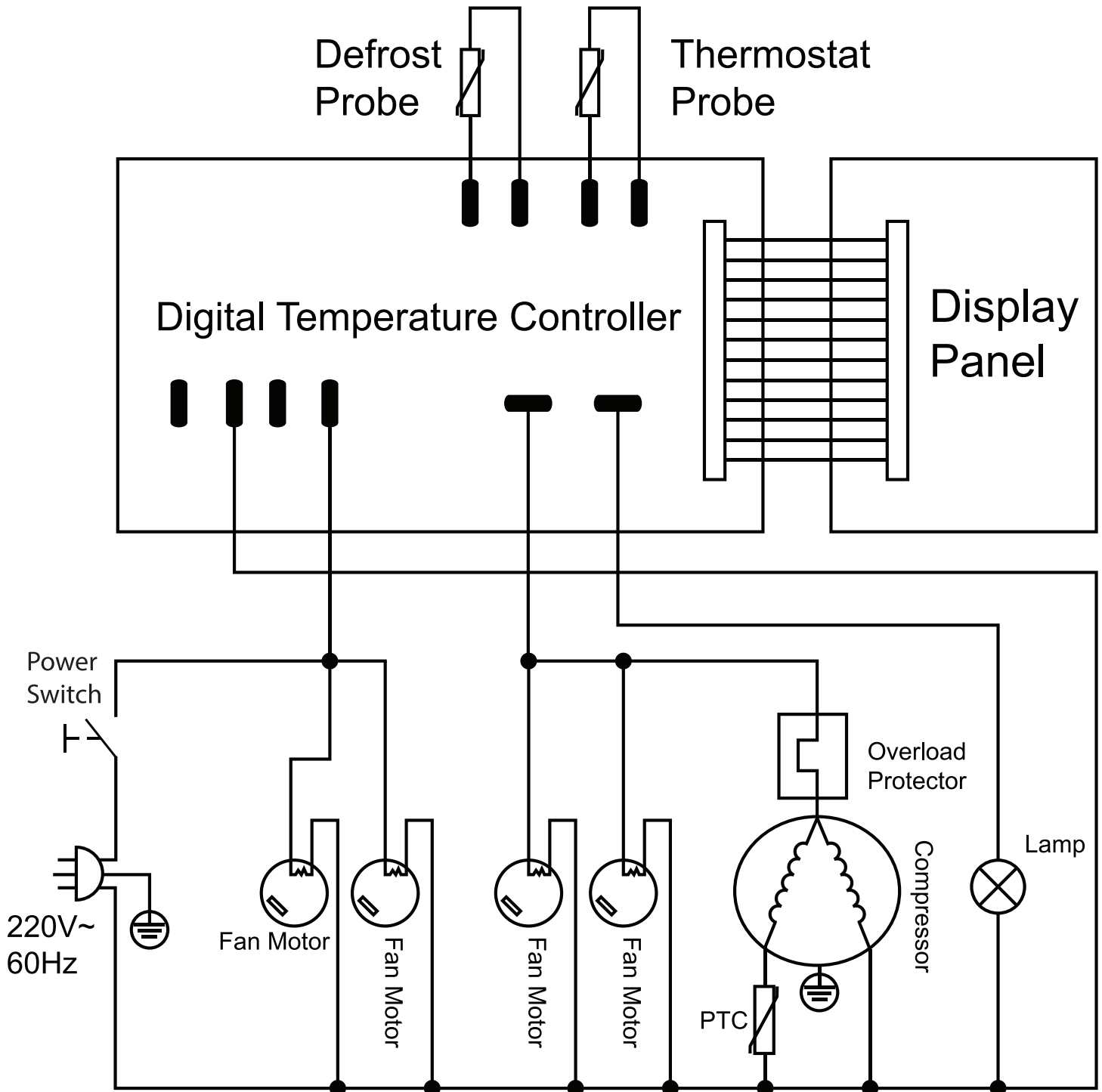



Warranty Registration

Thank you for purchasing an Omcan product. To register your warranty for this product, complete the information below, tear off the card at the perforation and then send to the address specified below. You can also register online by visiting:

Merci d'avoir acheté un produit Omcan. Pour enregistrer votre garantie pour ce produit, complétez les informations ci-dessous, détachez la carte au niveau de la perforation, puis l'envoyer à l'adresse spécifiée ci-dessous. Vous pouvez également vous inscrire en ligne en visitant:

Gracias por comprar un producto Omcan usted. Para registrar su garantía para este producto, complete la información a continuación, cortar la tarjeta en la perforación y luego enviarlo a la dirección indicada a continuación. También puede registrarse en línea en:

<https://omcan.com/warranty-registration/>

For mailing in Canada

Pour postale au Canada

Por correo en Canadá

OMCAN

PRODUCT WARRANTY REGISTRATION

3115 Pepper Mill Court,

Mississauga, Ontario

Canada, L5L 4X5

For mailing in the US

Pour diffusion aux États-Unis

Por correo en los EE.UU.

OMCAN

PRODUCT WARRANTY REGISTRATION

4450 Witmer Industrial Estates, Unit 4,

Niagara Falls, New York

USA, 14305

or email to: service@omcan.com



Purchaser's Information

Name: _____

Address: _____

City: _____ Province or State: _____ Postal or Zip: _____

Country: _____

Dealer from which Purchased: _____

Dealer City: _____ Dealer Province or State: _____

Invoice: _____

Model Name: _____ Model Number: _____

Machine Description: _____

Date of Purchase (MM/DD/YYYY): _____

Would you like to extend the warranty? Yes No

Company Name: _____

Telephone: _____

Email Address: _____

Type of Company:

Restaurant Bakery Deli

Butcher Supermarket Caterer

Institution (*specify*): _____

Other (*specify*): _____

Serial Number: _____

Date of Installation (MM/DD/YYYY): _____

Thank you for choosing Omcan | Merci d'avoir choisi Omcan | Gracias por elegir Omcan



Since 1951 Omcan has grown to become a leading distributor of equipment and supplies to the North American food service industry. Our success over these many years can be attributed to our commitment to strengthen and develop new and existing relationships with our valued customers and manufacturers. Today with partners in North America, Europe, Asia and South America, we continually work to improve and grow the company. We strive to offer customers exceptional value through our qualified local sales and service representatives who provide convenient access to over 5,000 globally sourced products.

Depuis 1951 Omcan a grandi pour devenir un des “leaders” de la distribution des équipements et matériel pour l’industrie des services alimentaires en Amérique du Nord. Notre succès au cours de ces nombreuses années peut être attribué à notre engagement à renforcer et à développer de nouvelles et existantes relations avec nos clients et les fabricants de valeur. Aujourd’hui avec des partenaires en Amérique du Nord, Europe, Asie et Amérique du Sud, nous travaillons continuellement à améliorer et développer l’entreprise. Nous nous efforçons d’offrir à nos clients une valeur exceptionnelle grâce à nos ventes locales qualifiées et des représentants de service qui offrent un accès facile à plus de 5000 produits provenant du monde entier.

Desde 1951 Omcan ha crecido hasta convertirse en un líder en la distribución de equipos y suministros de alimentos en América del Norte industria de servicios. Nuestro éxito en estos años se puede atribuir a nuestro compromiso de fortalecer y desarrollar nuevas relaciones existentes con nuestros valiosos clientes y fabricantes. Hoy con socios de América del Norte, Europa, Asia y América del Sur, que trabajan continuamente para mejorar y crecer la empresa. Nos esforzamos por ofrecer a nuestros clientes valor excepcional a través de nuestro local de ventas y representantes de los servicios que proporcionan un fácil acceso a más de 5,000 productos con origen a nivel mundial.

