



DONE TO PERFECTION.

INSTALLATION & OPERATIONAL MANUAL

English & French



LG SERIES GAS FRYERS

MODELS:

LG300

ML-136528

LG400

ML-136622

LG500

ML-136643

For additional information on Vulcan-Hart or to locate an authorized parts and service provider in your area, visit our website at www.vulcanequipment.com

IMPORTANT FOR YOUR SAFETY

THIS MANUAL HAS BEEN PREPARED FOR PERSONNEL QUALIFIED TO INSTALL GAS EQUIPMENT, WHO SHOULD PERFORM THE INITIAL FIELD START-UP AND ADJUSTMENTS OF THE EQUIPMENT COVERED BY THIS MANUAL.

POST IN A PROMINENT LOCATION THE INSTRUCTIONS TO BE FOLLOWED IN THE EVENT THE SMELL OF GAS IS DETECTED. THIS INFORMATION CAN BE OBTAINED FROM THE LOCAL GAS SUPPLIER.

IMPORTANT

IN THE EVENT A GAS ODOR IS DETECTED, SHUT DOWN UNITS AT THE MAIN SHUTOFF VALVE AND CONTACT THE LOCAL GAS COMPANY OR GAS SUPPLIER FOR SERVICE.

FOR YOUR SAFETY

DO NOT STORE OR USE GASOLINE OR OTHER FLAMMABLE VAPORS OR LIQUIDS IN THE VICINITY OF THIS OR ANY OTHER APPLIANCE.

WARNING

Improper installation, adjustment, alteration, service or maintenance can cause property damage, injury or death.

Read the installation, operating and maintenance instructions thoroughly before installing or servicing this equipment.

TABLE OF CONTENTS

IMPORTANT FOR YOUR SAFETY.....	2
INTRODUCTION.....	4
GENERAL.....	4
ORDERING PARTS.....	4
FRYER CAPACITIES.....	4
UNPACKING.....	4
INSTALLATION.....	5
Clearances.....	5
Location.....	5
Flue Installation.....	6
CODES AND STANDARDS.....	6
ASSEMBLY.....	7
FLUE EXHAUST.....	8
GAS CONNECTION.....	8
Quick-Disconnect for Units on Casters.....	9
GAS PRESSURE.....	9
TEST GAS SUPPLY.....	9
FRYERS WITH CASTERS.....	9
LEVELING THE FRYER.....	10
OPERATION.....	10
OVER-TEMPERATURE SHUTDOWN.....	11
BEFORE FIRST USE.....	11
Cleaning.....	11
FILLING TANK WITH SHORTENING.....	11
LIGHTING THE PILOT.....	12
TURNING ON THE FRYER.....	13
TURNING OFF THE FRYER.....	13
EXTENDED SHUTDOWN.....	14
BASIC FRYING INSTRUCTIONS.....	14
Fry Basket Guidelines.....	14
EXTENDED SHORTENING LIFE.....	14
DRAINING THE TANK.....	15
DAILY FILTERING-ALL MODELS.....	15
CLEANING.....	15
Daily.....	15
BOIL OUT PROCEDURE.....	16
MAINTENANCE.....	17
FLUE VENT INSPECTION.....	17
Service in the US and Canada.....	17
In Australia.....	17
TROUBLESHOOTING.....	17
Troubleshooting Chart.....	17
WARRANTY.....	18

INTRODUCTION

GENERAL

Vulcan Fryers are produced with quality workmanship and material. Proper installation, usage and maintenance will result in years of satisfactory performance.

Before installing the fryer, thoroughly read this manual and carefully follow all instruction.

This manual is applicable to model listed on the cover page. Procedures in this manual will apply to all models unless specified. Pictures and illustrations can be of any model unless the picture or illustration needs to be model specific.

ORDERING PARTS

To speed up your order, provide the model number, serial number, gas type, part needed, item part number (if known) and quantity needed.

FRYER CAPACITY				
MODEL	# of Heat Tubes	BTU/hr.	Width Inch (cm)	Shortening lbs. (kg)
LG300	3	90,000	15.5 (39)	35-40 (16-18)
LG400	4	120,000	15.5 (39)	45-50 (21-23)
LG500	5	150,000	21.0 (53)	65-70 (29-32)

UNPACKING

This fryer was inspected before leaving the factory. The carrier assumes full responsibility for the safe delivery upon acceptance of the shipment. Check for possible shipping damage immediately after receipt.

If the fryer is found to be damaged, complete the following steps:

1. Carrier must be notified within 5 business days of receipt.
2. Carrier’s local terminal must be notified immediately upon discovery (note time, date, and who was spoken to), and follow up and confirm with written or electronic communication.
3. All original packing materials must be kept for inspection purposes.
4. The fryer cannot have been moved, installed, or modified.
5. Notify Vulcan Customer Service immediately at 800-814-2028.

Check that the following have been included:

- ◆ Crumb Rack
- ◆ Basket Hanger
- ◆ Adjustable Legs (4)
- ◆ Drain Pipe Extension
- ◆ Twin Fry Baskets (2)
- ◆ Manual and Warranty – Retain for future reference.

Do not use the door or its handle to lift the fryer.

INSTALLATION

Before installing the fryer, verify that the type of gas (natural or propane) agrees with the specifications on the fryer data plate, which is located on the inside of the door panel. Make sure the fryer is configured for the proper elevation.

Record your fryer model, device, and serial numbers for future reference in the space provided below. This information can be found on the fryer data plate.

Fryer Model No: _____

Device: _____

Serial No: _____

Clearances

- ◆ Minimum clearance from combustible construction:
 - 6" (15 cm) from the sides of the fryer
 - 6" (15 cm) from the back of the fryer
 - The fryer may be installed on combustible floors
- ◆ Minimum clearance from noncombustible construction:
 - 0" from the sides of the fryer
 - 0" from the back of the fryer
- ◆ Between the fryer and any open-top flame units:
 - 16" (41 cm)
- ◆ Allow space for servicing and operation.

Location

- ◆ Install fryer in an area with sufficient air supply for gas combustion at fryer burners.
- ◆ Do not obstruct the flow of combustion and ventilation air.
- ◆ Provide adequate clearance for air openings into the combustion chamber.
- ◆ Do not permit fans to blow directly onto fryer.
- ◆ Avoid wall-type fans, which create cross-currents within a room. Avoid open windows next to sides or back.
- Electrical diagram located on inside of door.

⚠ WARNING **FLUE INSTALLATION: BEFORE USING FRYER INSTALL AND ASSEMBLE THE 10-5/8" FLUE TO THE FRYER..**

1. Unpack the flue box and flue wrap



2. Slide the flue box over the flue and secure it with the two self-tapping screws using a 5/16" socket

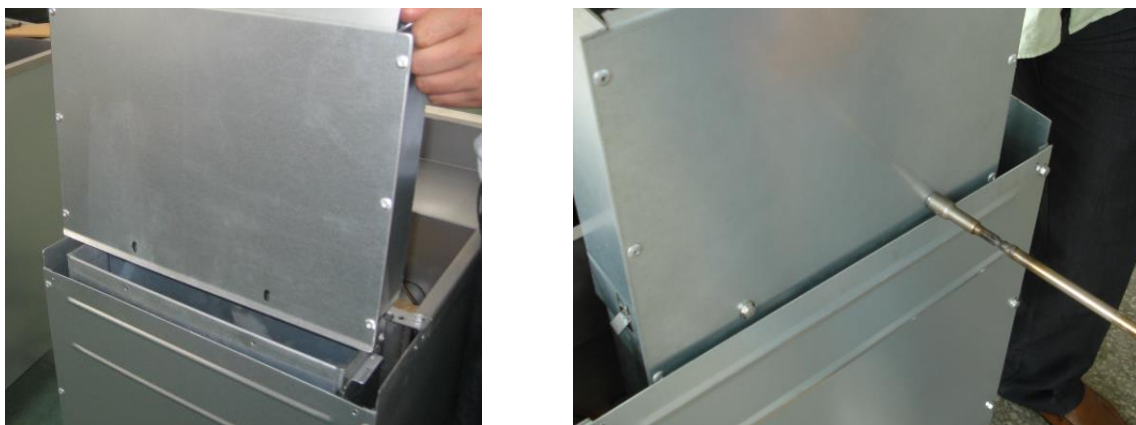

3. Slide the flue wrap over the flue



4. Secure it with four self-tapping screws two on the back and one on each side using a 5/16" socket



CODES AND STANDARDS

The fryer must be installed in accordance with:

In the United States:

- ◆ State and local codes, or in the absence of local codes, with:
- ◆ National Fuel Gas Code, ANSI-Z223.1/NFPA #54 (latest edition). Copies may be obtained from The American Gas Association Accredited Standards Committee Z223, @ 400 N. Capital St. NW, Washington, DC 20001 or the Secretary Standards Council, NFPA, 1 Batterymarch Park Quincy, MA 02169-7471.
- ◆ NFPA Standard #96 Vapor Removal from Cooking Equipment, latest edition, available from the National Fire Protection Association, Batterymarch Park, Quincy, MA.
- ◆ In the commonwealth of Massachusetts all gas appliances vented through a ventilation hood or exhaust system with a damper or with a power means of exhaust shall comply with 248 CMR.

In Canada:

- ◆ Local codes
- ◆ CAN/CSA-B149.1 Natural Gas and Propane Code Installation (latest edition), available from the Canadian Gas Association 350 Sparks Street, Ottawa, Ontario Canada K1R 7S8.
- ◆ CSA C22.1 Canadian Electric Code L4W 5N6.

ASSEMBLY

The fryer must be restrained to prevent tipping and the splashing of hot liquid. The means of restraint may be the manner of installation, such as connection to a battery of appliances, installing the fryer in an alcove, or by separate means such as adequate ties.

FLUE EXHAUST

- ◆ Comply with *Vapor Removal from Cooking Equipment*, ANSI-NFPA Standard #96 (latest edition), available from the National Fire Protection Association, Batterymarch Park, Quincy, MA 02269.
- ◆ Locate the fryer under a hood with adequate connection to an exhaust duct. The hood must extend 6" (15 cm) beyond fryer on both sides.
- ◆ Clearance above the fryer should be adequate for combustion byproducts to be removed efficiently.
- ◆ An 18" (46 cm) minimum clearance should be maintained between the flue vent and the filters of the hood venting system.
- ◆ Never make flue connections directly to the fryer.
- ◆ Do not obstruct the flow of the gases from the appliance. Proper air balance should be maintained in the room.
- ◆ Ensure that your ventilation system does not cause a down draft at the fryer's flue opening. Down draft will not allow the fryer to exhaust properly and will cause overheating which may cause permanent damage. Damage caused by down draft will not be covered under equipment warranty. Never allow anything to obstruct the flue or ventilation exiting from the fryer flue. Do not put anything on top of flue area.

GAS CONNECTION

NOTICE All gas supply connections and any pipe joint compound must be resistant to the action of propane gases.

The gas inlet is located on the lower rear of the fryer. Codes require that a gas shutoff valve be installed in the gas line ahead of the fryer.

The gas supply line must be at least the equivalent of ½" (12.7 mm) iron pipe for single units and 1-1/4" (31.75 mm) for batteries. If using the optional quick-disconnect flex hose, ¾" (19 mm) iron pipe for single units.

Make sure the pipes are clean and free of obstructions, dirt, and piping compound. A battery requires one or two connections of appropriate size for the gas requirement.

⚠ WARNING Prior to lighting, check all joints in the gas supply line for leaks. Use soap and water solution. Do not use an open flame.

After piping has been checked for leaks, fully purge gas pipes to remove air.

GAS PRESSURES (ALL MODELS):

The gas pressure should be set at 4" W.C. (Water Column) (0.8 kPa) for natural gas and 10" W.C. (2.75 kPa) for propane gas. If incoming pressure exceeds ½ PSI (3.45 kPa), an additional pressure regulator must be installed.

TESTING THE GAS SUPPLY PIPING SYSTEM:

When test pressures exceed ½ PSI (3.45 kPa), the fryer and its individual shutoff valve must be disconnected from the gas supply piping system.

When test pressures are ½ PSI (3.45 kPa) or less, the fryer must be isolated from the gas supply piping system by closing its individual shutoff valve.

Fryers with Casters: (Restraining device does not come supplied with fryer or casters).

Separate instructions for installing casters are included with the casters:

- ◆ The installation shall be made with a connector that complies with the Standard for Connectors for Movable Gas Appliances, ANSI Z21.69 or Connectors for Moveable Gas Appliances, CAN/CGA-6.16, and a quick-disconnect device that complies with the Standard for Quick-Disconnect Devices for Use with Gas Fuel, ANSI z21.41 or Quick-Disconnect Devices for Use with Gas Fuel, CANI-6.9.
- ◆ When installing a quick disconnect you must also install a means for limiting the movement of the fryer. This restraining device will prevent the gas line or quick disconnect from being strained. The restraining device should be attached to the cutout on the back panel. See illustration for location. If disconnection of the restraining device is necessary for service or cleaning, reconnect the restraining device after the fryer is placed back into its original position.

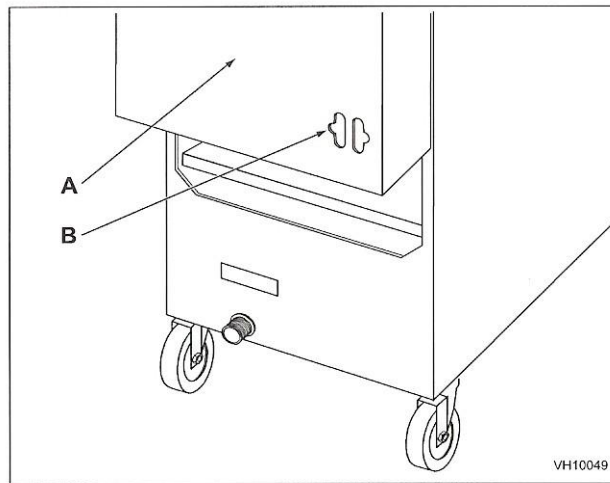

- A Rear of Fryer
- B Strain Relief Chain Connection
(Chain supplied by others)

- ◆ The fryer must be installed with a connector (not supplied by Vulcan) complying with the above codes.
- ◆ The fryer must be installed with restraining means to guard against transmission of strain to the connector. See illustration.
- ◆ The fryer must be installed with the casters provided.
- ◆ If the restraint is ever to be disconnected, first turn the gas supply off.

LEVELING THE FRYER

Check the level of the fryer by placing a level on top of the fryer after gas connections have been made.

Ensure that the fryer is level front-to-back and side-to-side in the final installed position.

If using casters, lock the wheels after unit is level.

OPERATION

▲ WARNING Hot oil and parts can cause burns. Use care when operating, cleaning and servicing the fryer.

▲ WARNING Spilling hot frying compound can cause severe burns. Do not move fryer without draining all frying compound from the tank.

OVER-TEMPERATURE SHUTDOWN

If the shortening becomes overheated, a high-temperature shutoff device will turn the gas valve off and extinguish the pilot.

If the fryer shuts down due to overheating, DO NOT relight the pilot until the shortening temperature is below 300° F (149 C).

If an overheating situation persists, contact your local Vulcan-Hart authorized service office.

BEFORE FIRST USE

Cleaning

New units are wiped down at the factory to remove any visible signs of dirt, oil, grease, etc. remaining from the manufacturing process.

Before any food preparation, thoroughly wash the protective oil from all surface parts and the tank interior with hot soapy water to remove any film residue and dust or debris.

NOTICE Do not use chlorine or sulfate/sulfide cleaners.

- ◆ Wash any accessories shipped with unit.
- Rinse fryer and accessories thoroughly and drain the fryer.
- ◆ Wipe tank completely dry with a soft, clean cloth.

FILLING TANK WITH SHORTENING

NOTICE Solid shortening should NOT be used with LG300 or LG400 fryers. Melting solid shortening will damage the tank and void your warranty.

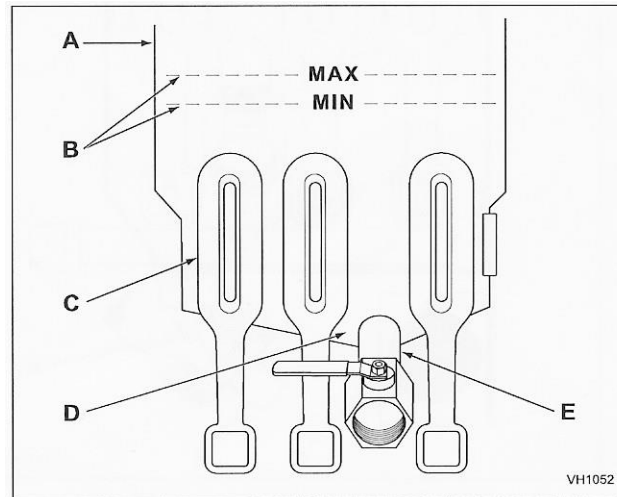

- A Fryer Tank
- B MIN and MAX Fill Level Lines
- C Heat Pipes
- D Cold Zone
- E Drain Pipe

- ◆ Close the drain valve.
- ◆ Fill the fryer tank with liquid shortening.
- ◆ Shortening level should be between the min and max lines in the fryer tank.
- ◆ Shortening will expand when heated. Do not fill the fryer tank past the MAX line.
- ◆ Add fresh shortening as needed to maintain oil level.

LIGHTING THE PILOT

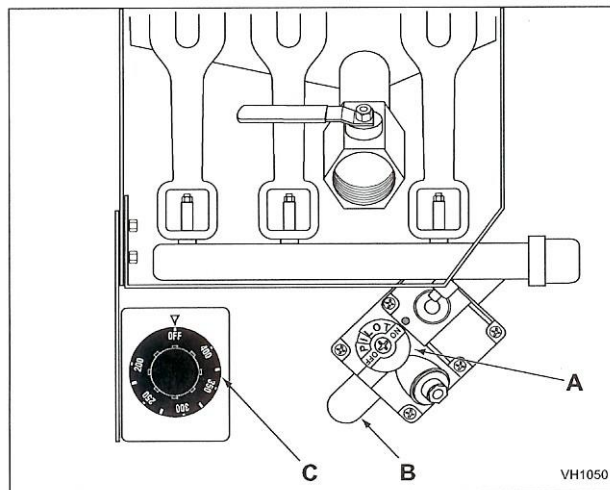

- A Gas Valve Knob
- B Gas Supply
- C Thermostat Knob

VULCAN LG FRYERS

1. Open the door.
2. Turn the thermostat OFF. The thermostat is located behind the door.
3. Push the gas control valve knob and turn to OFF (see figure below, view A). Wait 5 minutes for unburned gas to vent.
4. Push and turn gas control valve knob to the “L” in PILOT (see figure below, view B).
5. While still holding the knob in, light the pilot with a lit flame. Continue to depress the knob until pilot remains lit when knob is released. If the pilot does not remain lit, repeat step 3 through 5.
6. Depress and turn gas control knob to ON (See figure below, view C).
7. If gas supply is interrupted, repeat steps 2 through 6.

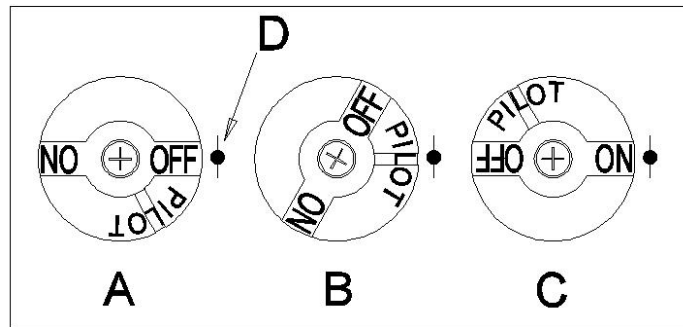

- A Gas Valve Knob, View A
- B Gas Valve Knob, View B
- C Gas Valve Knob, View C
- D Indicator Point, All Views

TURNING ON THE FRYER

- ◆ Set the temperature knob to desired temperature.
- ◆ After the set temperature has been reached, the thermostat shuts off the gas flow to burners.
- ◆ The pilot remains lit. The burners will cycle on and off, maintaining the set temperature.

TURNING OFF THE FRYER

1. Turn the thermostat OFF.
2. To keep the pilot lit, turn the gas valve to “L” in Pilot.
3. To shut off all gas to the system, including the pilot, turn the gas valve knob to OFF.

EXTENDED SHUTDOWN

1. Turn the thermostat knob to OFF.
2. Push in the pilot knob and turn to OFF.
3. Thoroughly drain the fryer. Refer to DRAINING THE FRYER.
4. Clean the fryer according to CLEANING.
5. Turn off the main gas shutoff valve.

BASIC FRYING INSTRUCTION

- ◆ Set the desired temperature and allow shortening to heat up to that temperature.
- ◆ Fry items that are the same size to ensure equal doneness.
- ◆ Drain or wipe dry raw or wet foods to minimize splatter when lowering into hot shortening.
- ◆ Add fresh shortening as needed.

Fry Basket Guidelines

- ◆ Do not overfill baskets. (See table for recommended basket capacities below)
Carefully lower basket into oil.
- ◆ When frying doughnuts and fritters, turn product only once during frying.
- ◆ When cooking French fries or onion rings, shake the basket several times.
- ◆ Batter-covered foods should be dropped carefully, one by one, into shortening or basket. If you use the basket, first dip the basket into the shortening to reduce batter-build up on basket surfaces.
- ◆ When frying is completed, remove basket or product. Hang basket on rear hanger.

Fry Basket Capacity:

LG300, LG400: Recommended pounds per basket are 1.5 lbs. (0.7 kg).
LG500 Recommended pounds per basket are 3.0 lbs. (1.4 kg).

EXTENDING SHORTENING LIFE

Shortening life can be extended by the following guidelines:

- ◆ Do not salt foods over the fryer.
- ◆ Use good-quality shortening.

- ◆ Filter shortening daily (at a minimum).
- ◆ Replace shortening if it becomes poorly flavored.
- ◆ Keep equipment and surrounding area clean.
- ◆ Set thermostat correctly.
- ◆ Remove excess moisture and particles from food products before placing on fryer.

DRAINING THE TANK

1. Turn the thermostat to OFF.
2. To keep the pilot lit, turn the gas valve to PILOT.
3. Direct the drain spout into the container that you want to drain the shortening into.
4. Open the drain valve. The oil will drain into the container. When the container is full or the fryer tank is empty, close the drain valve. Repeat this step until the fryer is empty.
5. If desired, perform the weekly clean-out as described under CLEANING.
6. Once tank is completely empty, add new shortening and set thermostat to desired temperature.

DAILY FILTERING

⚠ WARNING Hot oil and hot parts can cause burns. Use care when operating, cleaning, and servicing the fryer.

- ◆ Filter shortening at least once a day. Refer to the instructions provided with your filtering equipment.
- ◆ A cold fryer will not drain properly. Always filter shortening between 250°F and 350°F. The shortening in the cold zone area will remain hard if the heat is only on for a few minutes. If necessary, use the clean-out rod to carefully stir the hard shortening to an area above the cold zone where it will melt. Use the tank brush to help clear sides and tubes of debris.

CLEANING

⚠ WARNING Hot oil and hot parts can cause burns. Use care when operating, cleaning, and servicing the fryer.

Daily

Clean your fryer regularly with the tank brush along with a damp cloth, and polish with a soft dry cloth. If regular cleaning is neglected, grease will be burned on and discolorations may form.

Fingerprints are sometimes a problem on highly polished surfaces of stainless steel. They can be minimized by applying a cleaner that will leave a thin oily or waxy film.

- ◆ Clean all exterior surfaces of your fryer at least once daily.
- ◆ Use a damp cloth with warm water and a mild soap or detergent.

NOTICE Do not use chlorine or sulfate/sulfide cleaners.

- ◆ Rinse thoroughly, and then polish with a soft dry cloth.
- ◆ Keep the fryer exterior clean and free of accumulated grease to prevent stubborn stains from forming. If regular cleaning is neglected, grease will be burned on and discolorations may form.
- ◆ Remove discolorations by washing with any detergent or soap and water.
- ◆ Use a self-soaping, non-metallic scouring pad for particularly stubborn discolorations.
- ◆ Always rub with the grain of the stainless steel.
- ◆ Do not use a metallic scoring pad or harsh cleaners.

BOIL OUT PROCEDURE

Weekly or as required:

1. Drain the tank as described under DRAINING THE TANK.
2. Once the shortening has been drained, flush out scraps and sediment with a small amount of warm shortening, using tank brush. Allow the tank to drain thoroughly.
3. Close the drain valve and fill tank water. Use a low foaming cleaner/degreaser to clean the fry tank. Follow the instructions on the side of the package.

NOTICE Do not use chlorine or sulfate/sulfide cleaners.

4. Add commercial boil-out solution. Solution level must be between the MIN and MAX levels on the fryer tank.
5. Set thermostat to the temperature recommended for the solution being used. Do not exceed 200°F. Allow solution to simmer for about 15 to 20 minutes.
6. Drain the cleaning solution from the tank.
7. Close the drain valve and refill the tank with water. Add 1 cup (1/4 L) of vinegar to neutralize alkaline left by the cleaner. Solution level must be between the MIN and MAX level on the fryer tank.
8. Bring the solution to a simmer only, turn the thermostat off. Allow to stand for a few minutes.
9. Drain the tank according to DRAINING THE TANK. Rinse thoroughly with clear, hot water. All traces of cleaner must be removed. Dry the tank thoroughly.
10. Close the drain valve and add shortening. Follow the FILLING TANK WITH SHORTENING procedure in this manual. The fryer is now ready for use.

MAINTENANCE

⚠ WARNING Hot oil and hot parts can cause burns. Use care when operating, cleaning, and servicing the fryer.

⚠ WARNING Spilling hot fryer compound can cause severe burns. Do not move fryer without draining all frying compound from the tank.

FLUE VENT INSPECTION

When the fryer is cool, inspect annually. Check the flue and clear any obstructions.

Service in the US and Canada

Check www.vulcanequipment.com for the closest service office.

In Australia

Contact Hobart Food Equipment PTY. LTD., 16 Hilly Street Morlake, N.S.W. 2137 Australia; P.O. Box 100, Concord N.S.W. 2137; Tel: (02) 9736 1200; Fax: (02) 9736 1555.

www.hobartfood.com.au

Troubleshooting Chart:	
Problem:	Probable Cause:
No Heat:	Thermostat dial not turned on. Pilot not lit. Gas supply not turned on. Wire connections loose (call service) Wires connections need cleaning (call service) Thermopile (call service)
Insufficient or too much heat:	Thermostat dial not set to desired temperature. High limit tripped (call service) Temperature probe (call service)
Tank will not drain:	Shortening too cold. Drain pipe clogged with debris.



LIMITED ORIGINAL COMMERCIAL EQUIPMENT WARRANTY FOR THE LG SERIES GAS FRYERS

Vulcan warrants the LG Gas Fryer to be free of defects in materials and workmanship for a period of 1 year from the date of original installation.

This Warranty is subject to the following conditions and limitations:

1. This warranty is limited to product(s) sold by Vulcan to the original user in the continental United States and Canada.
2. Original installation must occur within 18 months of date of manufacture, and proof of the installation must be provided to Vulcan.
3. The liability of Vulcan is limited to the repair or replacement of any part found to be defective.
4. Vulcan will bear normal labor charges incurred in the repair or replacement of a warranted piece of equipment within 50 miles (80 kilometers) of an authorized service agency. Time and travel charges in excess of 50 miles (80 kilometers) will be the responsibility of the person or firm requesting the service.
5. This warranty does not apply to any product(s) which have not been installed in accordance with the directions published in the appropriate installation and operation manuals. Vulcan will bear no responsibility or liability for any product(s) which have been mishandled, abused, misapplied, misused, subject to harsh chemical action, (chlorinated or sulfate products), or poor water quality, field modified by unauthorized personnel, damaged by flood, fire, or other acts of nature, or which have altered or missing serial numbers.
6. Vulcan does not recommend or authorize the use of any product(s) in a non-commercial application, including but not limited to residential use. The use or installation of product(s) in non-commercial applications renders all warranties, expressed or implied, including the warranties of MERCHANTABILITY and FITNESS FOR A PARTICULAR PURPOSE, null and void, including any responsibility for damage, cost and legal actions resulting from the use or installation of product(s) in any non-commercial setting.
7. Adjustments such as calibrations, leveling, tightening of fasteners or utility connections normally associated with original installation are the responsibility of the installer and not that of Vulcan.
8. Exception to the 1 year warranty period is as listed:
 - Fry Tanks:
 - If tank is found to be leaking within the first year of operation from date of installation and verified by an authorized service agency, the entire LG fryer will be replaced. Replacement fryer will be warranted for the balance of the original warranty. Fry tanks found to be leaking that are over 1 year and under 3 years, 50% of the current selling fry tank price, plus labor, freight and mileage will be the responsibility of the person or firm requesting the service. Fry tanks found to be leaking that are over 3 year and under 5 years, 75% of the current selling fry tank price, plus labor, freight and mileage will be the responsibility of the person or firm requesting the service. After 5 years – no fry tank part warranty.
9. Original purchased replacement parts manufactured by Vulcan will be warranted for 90 days from the parts invoice date. This warranty is for parts cost only, and does not include freight or labor charges. Exceptions are stainless steel fry tanks which will be warranted as stated in item 8.
10. This states the exclusive remedy against Vulcan relating to the product(s), whether in contract or in tort or under any other legal theory, and whether arising out of warranties, representations, instructions, installations or defects from any cause. Vulcan shall not be liable, under any legal theory, for loss of use, revenue or profit, or for substituted use or performance, or for incidental, indirect, or special or consequential damages or for any other loss of cost of similar type.
11. THIS WARRANTY AND THE LIABILITIES SET FORTH HEREIN ARE EXCLUSIVE AND IN LIEU OF ALL OF THEIR LIABILITIES AND WARRANTIES, EXPRESSED OR IMPLIED, INCLUDING BUT NOT LIMITED TO, IMPLIED WARRANTIES OR MERCHANTABILITY AND FITNESS FOR PARTICULAR PURPOSE AND CONSTITUTES THE ONLY WARRANTY OF VULCAN WITH RESPECT TO THE PRODUCT(S).