

RXSU-72-18

72" Triple Door Sandwich Prep Table

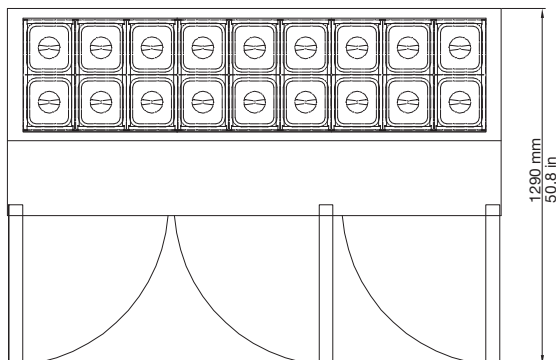

- Stainless steel interior and exterior, aluminum back. Option of bright white aluminum interior available.
- Refrigeration system keeps food at safe temperatures between 33°F and 41°F (0.5°C to 5°C).
- Self-Closing doors with 90 degree stay-open feature.
- Shelves: Adjustable heavy-duty PVC coated shelves.
- Cutting boards and pans available.
- Option of different handles available.
- Electronic control system makes it easy to adjust temperature set point and defrost frequency.
- Preinstalled heavy-duty casters with brakes.
- Removable installation board makes it easy to access condenser coil for cleaning and service.
- Refrigerant: HYDRO-CARBON R290.

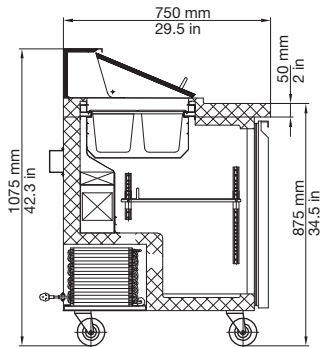
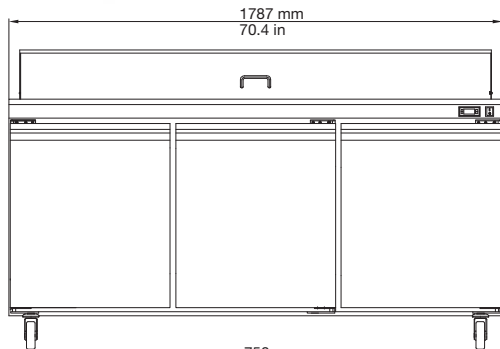

SPECIFICATIONS	RXSU-72-18
Exterior Dimensions WxDxH (in)	70.4 x 29.5 x 42.3
Interior Dimensions WxDxH (in)	66 x 24 x 24
Packing Dimensions WxDxH (in)	75 x 34 x 46
Interior Volume (gross) cu ft	15.5
Temperature Range (F)	33°F - 41°F
Compressor Power (HP)	3/4
Refrigerant	R290
Isolation Material	Polyurethane (C-PENTANE)
Cooling System	Ventilated
Defrosting	Automatic
Net Weight lbs	343
Shipping Weight lbs	525
Temperature Display	Yes
Doors	3
Self Closing Door	Yes
Lock Mounted	No
Shelves	3
Housing Material	SS430
Door/Lid Material	SS430
Liner Material	SS304
Shelf Material	Plastic Coated Steel
Type of Controller	Digital
Shelf Loading lbs/pc	90
Climate Rating (°F)	100
Connection Rating Amp/Watts	8.9 amps
Voltage/Frequency	115V/60HZ

Specifications subject to change without notice. Dimensions rounded up to the nearest 1/8".

Warranty: 1 year parts and labour; 5 year compressor.

