



AFCT-15

Hand polished stainless steel finish

STANDARD FEATURES

- Cooks 20-22 lbs. of fries per hour.
- Snap-acting mechanical thermostat holds oil temperature accurately at any temperature between 200°F to 400°F.
- 30,000 BTU/hr. Infrared burners provide fast recovery.
- Large “cool zone” captures stray food and breading, keeping them out of the frying area to improve food taste and prolong oil life.
- All stainless steel tanks are precision welded and tested for optimum seal.
- Two fryer baskets.
- Stainless steel fry vessel with sloped bottom.
- Stainless steel exterior standard.
- Millivolt burner requires no electrical connection.
- 16 gauge Stainless steel tank.
- High limit provides 100% safety shut-off.
- 4” adjustable legs.
- NG or LP gas operation.
- 1/2” drain tube.
- Optional Items - Stainless steel fryer vat cover.
- One year limited warranty, parts and labor.



The Professional Gas Counter Top Fryer by American Range features a unique sloped tank design that creates a large heat transfer area. This means oil is quickly heated to desired temperatures, recovery time is minimized, and food debris easily slides down to the cool zone. The cool zone reduces wasteful oil breakdown by keeping debris out of the high temperature cooking area. The AFCT-15 sloped 1/2 inch diameter

front drain makes draining quick and easy. The fryer tank and exterior are constructed from the highest quality stainless steel. The American Range Professional Countertop Fryer is equipped with a snap-acting thermostat with a 200°F to 400°F range for temperature controls and a 100% safety shut-off and automatic reset button.

COUNTERTOP FRYER PROFESSIONAL SERIES

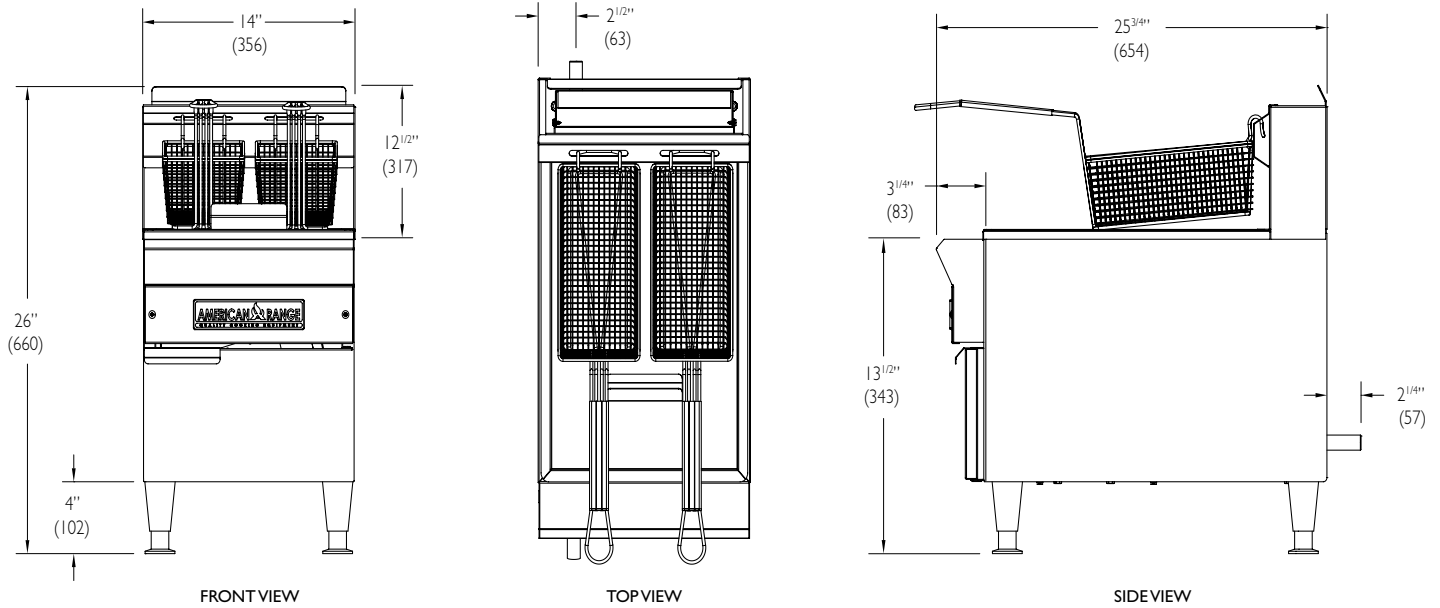

SCALE: NOT TO SCALE

Model	Width	Depth	Height	Burners	Total BTU	KW	Shipping Weight	Lbs.	Kg.
AFCT-15	14"	25 3/4"	26"	1	30,000	9	95	43	

STANDARD FEATURES

- Cooks 20-22 lbs. of fries per hour.
- Snap-acting mechanical thermostat holds oil temperature accurately at any temperature between 200°F to 400°F.
- 30,000 Btu/hr Infrared burners provide fast recovery.
- Large "cool zone" captures stray food and breading, keeping them out of the frying area to improve food taste and prolong oil life.
- All stainless steel tanks are precision welded and tested for optimum seal.
- Two fryer baskets.
- Stainless steel fry vessel with sloped bottom.
- Stainless steel exterior standard.
- Millivolt burner requires no electrical connection.
- 16 gauge Stainless steel tank
- High limit provides 100% safety shut-off.
- 4" adjustable legs.
- 1/2" drain tube.
- NG or LP gas operation.
- One year limited warranty, parts and labor.

OPTIONAL FEATURES

- Stainless steel fryer vat cover.

CUT AWAY VIEW OF SLOPED DRAIN & TANK

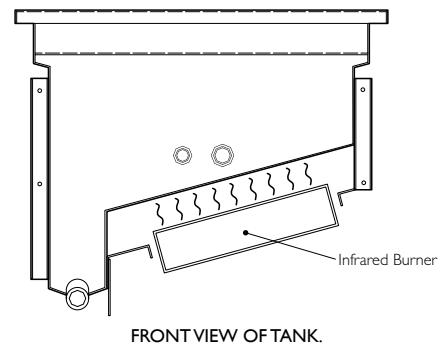

SCALE: NOT TO SCALE

GaS SUPPLY: 3/4" NPT Gas inlet 7" to 9" W.C. Manifold pressure is 5.0" W.C. for natural gas, or 11" - 12" Manifold pressure is 10.0" W.C. for propane gas. Specify type of gas and altitude if over 2000 feet.

CLEARANCES: For use only on non-combustible floors. Legs or casters are required, or 2" (51) overhang is required when curb mounted. Clearance from non-combustible walls is 0". When unit is placed next to combustible walls, clearances must exceed 12" (305) on sides, and 4" (102) from rear. Radiant broilers for non-combustible locations only.

*The American Range Company continually improves its products and reserves the right to change materials, specifications and dimensions without notice. This unit is manufactured for commercial use only.