

## Professional Blender

Heavy-Duty, 3HP Motor,  
Premium BPA-Free Container

### REL-TM-788

**POWER:** Designed and built to purée and blend the toughest ingredients

**DURABILITY:** Rugged construction designed to outlast other blenders 5 to 1

- 3HP high speed industrial motor
- Premium, virtually unbreakable BPA-Free container
- High/Low, 2-speed
- 2-in-1 stainless steel cutting blade
- Wet and dry applications
- Crushes ice in seconds
- Multi function, precision technology

Voltage: 120v~

Frequency: 60hz

Power: 1050w

Capacity: 2-litre / 68 oz / 8.5-Cup

Dimensions (LxWxH): 20cmx24cmx51cm (13"x9"x11")

N.W.: 4.3 Kgs (9.5 Lbs)

G.W.: 4.7 Kgs (10.3 Lbs)



**New and Improved  
Cutting Blade**

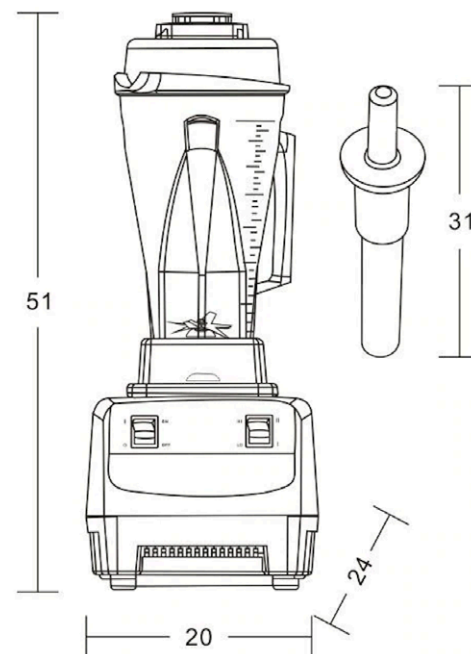

Specifications subject to change without notice.



For complete information and specifications on all Reliant products, visit [www.paragondirect.ca](http://www.paragondirect.ca)