

## RXSU-36-10

### 36" Double Door Sandwich Prep Table

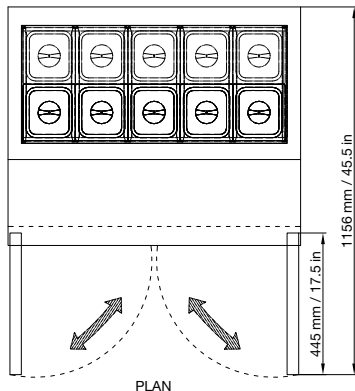

- Stainless steel interior and exterior, aluminum back.
- Option of bright white aluminum interior available.
- Refrigeration system keeps food at safe temperatures between 33°F and 41°F (0.5°C to 5°C).
- Self-Closing doors with 90 degree stay-open feature.
- Shelves: Adjustable heavy-duty PVC coated shelves.
- Cutting boards and pans available.
- Option of different handles available.
- Electronic control system makes it easy to adjust temperature set point and defrost frequency.
- Preinstalled heavy-duty casters with brakes.
- Removable installation board makes it easy to access condenser coil for cleaning and service.
- Refrigerant: Environmentally-friendly Hydro-Carbon R290.

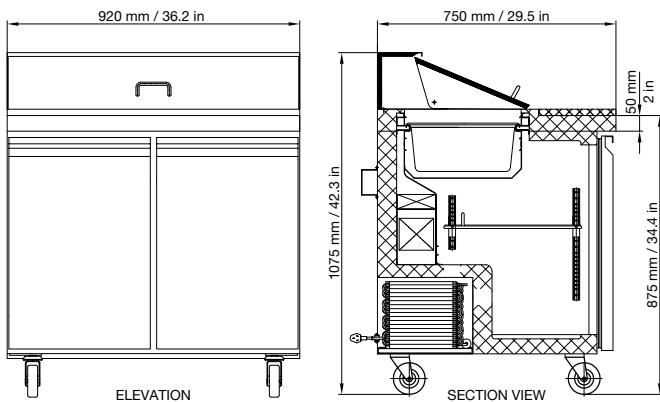

Exterior Dimensions WxDxH	36x30x42 in
Interior Dimensions WxDxH	33x24x24 in
Packing Dimensions WxDxH	44.5x34x46 in
Interior Volume cu ft	7.6
Temperature Range (F)	32°F-50°F
Compressor Power (HP)	1/5
Refrigerant	R290
Isolation Material	Polyurethane (C-PENTANE)
Cooling System	Ventilated
Defrosting	Automatic
Net Weight lbs	220
Shipping Weight lbs	260
Temperature Display	Yes
Doors	2
Self Closing Door	Yes
Lock Mounted	No
Shelves	2
Exterior Material	SS430
Interior Material	SS304
Shelf Material	Plastic Coated Steel
Type of Controller	Digital
Shelf Loading lbs/pc	90
Climate Rating (F)	100
Connection Rating Amp/Watts	5.2
Voltage/Frequency	115V/60HZ

Specifications subject to change without notice. Dimensions rounded up to the nearest 1/8".

**Warranty: 1 year parts and labour; 5 year compressor.**

